

# VMC 101

## TWIN AUDIO/VIDEO - MODULATOR

A/V ATV (AM) Standards B/G, D/K, I, L, M

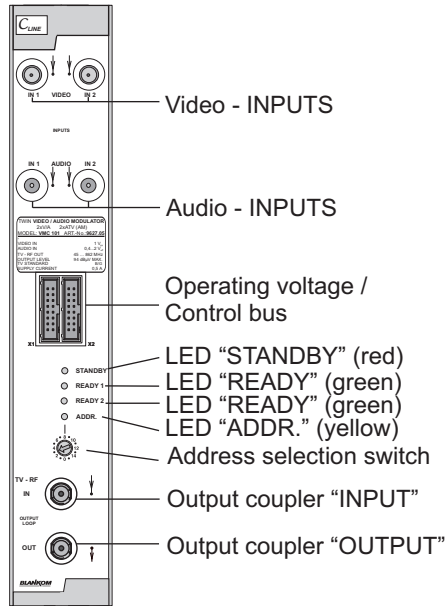

Fig. 01

### Device Variants

VMC 101 9627.05 2 x A/V x VHF / UHF [47 ... 862 MHz]

### GENERAL

The TWIN A/V - Modulator VMC is a module of the C-LINE+ headend system and is distinguished by the unique **ITT - Independent Twin Technology**. The C-LINE+ system is optimal for small and medium community networks and offers excellent performances. The VMC 101 modulates TWO analogue Audio and Video signals into TWO analogue Cable-TV - signals (PAL, SECAM, NTSC). The signals can be selected and adjusted fully independently from each other within TWICE the range of 47 - 862 MHz. The module can be programmed and adjusted via a central control unit (Headend Controller / HCB 100) manually or remotely and operates independently after adjustments. The status of each module(channel) is displayed via a colored LED:

- Red - STANDBY Standby mode
- Green - READY 1, 2 Operating mode, channel 1, 2
- Yellow - ADDR Remote access

### FUNCTION DESCRIPTION

The VMC 101 TWIN - Modulator is an agile TWIN A/V - Modulator and is used for modulation of TWO Audio/Video - signals (from any A/V - source) into TWO analogue cable-TV channels within the range of 2 x 47...862 MHz (PAL/SECAM/NTSC). The received A/V - signals will be modulated by modulator 1 & 2 into the respective IF - carriers (Vestigial sideband modulation). The IF - carriers will be converted into the desired cable-TV channel (2 x 47...862 MHz) by the following TWIN-converter. The output channel can be freely selected twice within the range of 47 - 862 MHz (the device is fully adjacent channel sufficient) TWO independent operating TV-channels are available at the output which levels can be also freely adjusted. The outputs are designed in loop trough technique so no additional combiners, splitters are necessary.

### PROGRAMMING (MANUALLY)

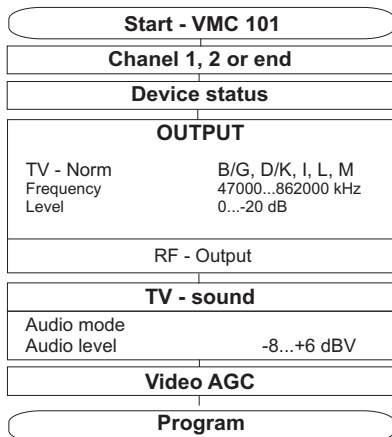

Fig. 02

### Adjustment with the headend controller

Adjustment of the addresses at the bus extender BEB 100 and at the modules  
 Activation of the programming mode of each module by selecting the line (BEB 100) and the module position (01... 15) at the head end controller(HCB 100)  
 yellow LED will be lit up til the beginning of the parameter adjustment  
 Adjustment of the VMC 101 parameter (see fig.02)  
 green LED is lit up  
 After the programming the VMC 101 will be automatically switched into the operating status  
 yellow LED lights up briefly / green LED is lit up

### Adjustment with the PC / Laptop

Condition for the remote programming is an "online - connection" after IP - standard and an ethernet connection at the PC / Laptop  
 Adjustment of the line / position addresses at the bus extender BEB 100 as well as at the modules  
 At the head end controller HCB 100 IP - address input (e.g. 192.168.002.080)  
 For "direct connection" between a PC and HCB 100 use a crossed patch cable (RJ 45)  
 For connection over a deviation use an uncrossed patch cable  
 HTML - browser start-up and put in IP - address as target address  
 If connected correctly the HTML - control surface at the PC will open up and a green LED (LINK) at the HCB 100 will be lit up  
 All adjustment of the modules are specified at the control surface a blue LED (LINK) at the HCB 100 will be lit up

**The manual instructions of the head end controller HCB 100 and the bus extender BEB 100 have to be considered!**

## TECHNICAL DATAS

### Video - Input

Input voltage without AGC	1 V <sub>ss</sub>
Input voltage with AGC	0,5...2 V <sub>ss</sub>
AGC reference	Sync. - amplitude
Impedance	75
Connector	Cinch - socket

### Audio - Input

Input level	-8...+6 dBV
Input impedance	>10 k
Connector	3,5 mm - Stereo- socket
Configuration	unsymmetrical

### TV - Output

TV - Standard (PAL/SECAM/NTSC)	B/G, D/K, I, L, M
Sound procedure (B/G, D/K)	FM - dual carrier procedure
	Mono / Stereo / Dual / Auto
Sound procedure (I, L, M)	Mono
max. Output level	94 dB $\mu$ V
Signal to Noise (S/N)	> 60 dB
Level adjustment grid	20 dB (0,5 dB - steps)
Impedance	75
Connector	F - socket
Loop through attenuation	1,5 dB
Output frequency range	2 x 47 ... 862 MHz
Tuning grid	125 kHz

### Operating parameter

Voltage / Current	12 V ( 0,2 V ) / 550 mA
Residual ripple of voltage supply	10 mV <sub>ss</sub>

### Environmental conditions

Temperature rang	-10 ... +55 °C
Relative humidity	80 % (not condensating)
Mounting	vertical
Mounting location	Dry and splash proof

### Physical conditions

Dimensions (W x H x L)	
without 19" - Adapter	50 x 276 x 148 mm
with 19" - Adapter	50 x 301 x 148 mm
Weight	1.300g

### Delivery content

1 x BUS - connection cable
2 x Audio - connection cable
2 x Video - connection cable
2 x Adapter
1 x F - connection cable 140 mm

## HEAD END BUS STRUCTURE

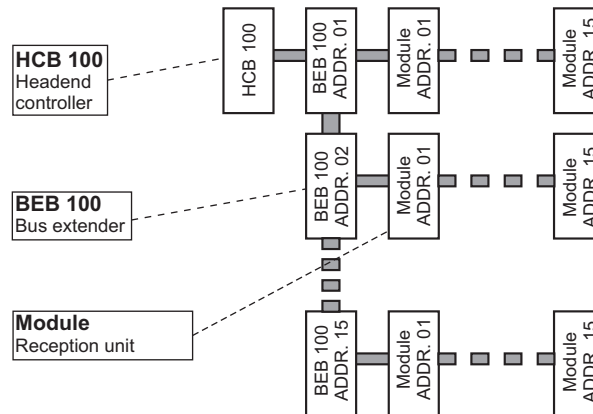

The number of the possible module connections (00 ... 15) to a BEB 100 depends on the total power consumption of this line!

Fig. 03

## SECURITY AND OPERATING INSTRUCTIONS

**STOP** When assembling, starting-up and adjusting the modules, it is necessary to consider the system specific references in the manual instruction!

- ⚠ The modules may only be installed and started up by authorized technical personnel!
- ⚠ When assembling the modules into the receiving points, the adherence of the EMV regulations is to be secured!
- ⚠ The assembly and wiring have to be done without voltage!
- ⚠ All active modules may only be operated with the head end controller HCB 100 or bus extender BEB 100!
- ⚠ The main voltage for all power supply units is 230 V, 50 Hz.
- ⚠ With all work the defaults of the DIN EN 50083 have to be considered!
- ⚠ Especially the safety relevant execution of the DIN EN 50083/1 is necessary!

Options and other TV standards available upon request!

Changings due to technical processes are possible.

Part n°: 9627.05

**BLANKOM** Antennentechnik GmbH

Hermann - Petersilge - Str. 1 07422 Bad Blankenburg Germany Phone +49 (0) 36741/ 60-0 Fax +49 (0) 36741/ 60-100