

## Device manual



### Audio/ Video Modulator

A/V → ATV (AM)



**VMA 191**  
**Part N°: 9228.8x/ .9x**

*...Setting Signals*

**Contents**

1. Safety and operating instructions ..... 3

2. Device variants ..... 3

3. General ..... 3

4. Functional description..... 3

5. Explanation of the operating elements ..... 4

    5.1 Front view ..... 4

    5.2 Meaning of the LED signals..... 4

    5.3 Front panel keypad and tuning wheel ..... 4

    5.4 Rear view ..... 5

    5.5 9-pin D-SUB connector configuration (alarm contact) ..... 5

    5.6 Audio socket ..... 5

    5.7 Factory settings ..... 6

6. Programming by web server ..... 6

    6.1 Network connection to computer ..... 6

    6.2 Device status ..... 7

    6.3 Standard settings..... 7

    6.4 Extended settings ..... 8

    6.5 Software overview ..... 8

    6.6 IP network ..... 9

7. SNMP management ..... 10

    7.1 Download MIB ..... 10

    7.2 Trap messages ..... 10

8. Menu structure of display handling..... 11

9. Block diagram ..... 12

10. Technical data .. ..... 12

11. Glossary ..... 13

12. Bibliography ..... 13

13. Document history ..... 13

## 1. Safety and operating instructions



When assembling, starting-up and adjusting the modules, it is necessary to consider the system specific references in the manual instruction!



The modules may only be installed and started up by authorized technical personnel!



When assembling the modules into the receiving points, the adherence of the EMC regulations is to be secured!



The assembly and wiring have to be done without voltage!



With all work the defaults of the DIN EN 50083 have to be considered! Especially the safety relevant execution of the DIN EN 60728-11 [1] is necessary!



The devices come under protection classification I. It is absolutely necessary, therefore, to insert the mains plug into a socket with protective contact

## 2. Device variants

VMA 191	9228.82	A/V → IFI → ATV (AM) Norm B/G
VMA 191	9228.85	A/V → IFI → ATV (AM) Norm M
VMA 191	9228.91	A/V → IFI → ATV (AM) Norm D/K 1*
VMA 191	9228.92	A/V → IFI → ATV (AM) Norm D/K 2*
VMA 191	9228.94	A/V → IFI → ATV (AM) Norm D/K 4*

\* D/K 1: standard D/K with sound carrier 6.5 MHz and 6.25 MHz

D/K 2: standard D/K with sound carrier 6.5 MHz and 5.74 MHz

D/K 4: standard D/K with sound carrier 6.5 MHz

## 3. General

The Audio/ Video Modulator VMA 191 is a module of the head end system A-LINE which is conceived as a complete system for big and middle-sized networks. The VMA 191 generates an analogue TV signal in whole cable frequency range.

## 4. Functional description

The video processing contains a video low pass with a sound trap, a group delay-pre-equalization, clamping circuit and a switchable video AGC. The video AGC function requests one white pulse per field in any line within the source signal (white level adjustment control); alternatively AGC has to be deactivated. The magnitude of the residual carrier is determined by video amplitude of the input signal in this case. The audio processing contains a symmetric input amplifier, an audio low pass, a level setting element and a switchable audio summing unit in the 9228.85 respectively a switchable stereo/ dual tone-coder otherwise. These unit respectively coder allows remote accesses manually, VPS controlled or via corresponding contacts into the audio socket (see chapter 5.6). There is the possibility to configure an asymmetric audio input. An electronically switch connects pin 4 and 5 inside the device on ground. Analog video and audio signals are fed to separate modulators and summarized at IF mixer. After IF filtering follows the conversion in the wanted output channel by the help of a duplex frequency conversion. The operation of high level mixers and fractional N-PLL's assure a high output performance. The output channel is free adjustable between 45...862 MHz. The modulator is adjacent channel fitted. For level error reporting a reference level is generated internally and is compared with current value permanently. After each programming of the level and/or frequency values an automatic measurement of the reference level takes place. The monitoring of the input signal is done at the output of the VMA 191. If the IF loop is activated the IF input is weighted.

The integrated management unit consists of the data interface for PC/LAN/WAN (IP/ Ethernet interface / RJ 45). The management of the module can be done via PC/Laptop (see programming). The status of the module will displayed with LEDs (see section 5.2 "Meaning of the LED signals"). The IP address of each device can be edited and adjusted to the respective LAN.

## 5. Explanation of the operating elements

### 5.1 Front view

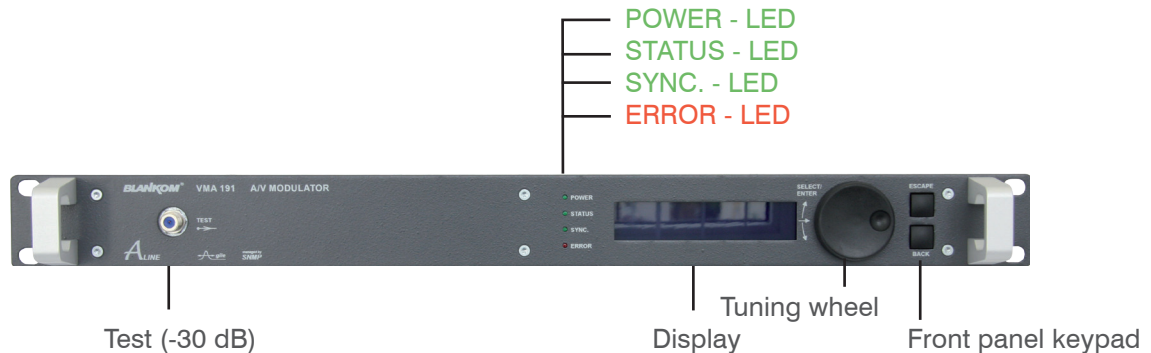

### 5.2 Meaning of the LED Signals

Designation (Colour)	Status	Meaning of display
POWER (green)	permanently on	Device is ready for working
	off	Device is off, without current supply
STATUS (green)	permanently on	Device working properly
	off	RF output is deactivated
SYNC. (green)	permanently on	Video input is ok
	flashing	Video input is not ok (e.g. in case of missing input signal)
ERROR (red)	permanently on	Device is in standby
	flashing	Device is faulty (hardware error)

### 5.3 Front panel keypad and tuning wheel

ESCAPE



By activating the ESCAPE-Pad you exit the current menu cycle. The input function switches back to the inactive status and jumps to the status information (Start display)



BACK

By activating the BACK-Pad you leave the current mode (Menu selection) without any acceptance of settings or adjustments. The cursor jumps one menu level higher.

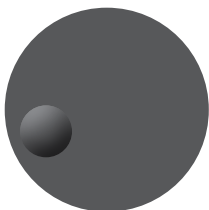

Pressing of the tuning wheel is equivalent to the ENTER-Function.

The cursor switches to the active mode. Tuning the wheel right or left enables to select an menu entry, the menu selection will be confirmed by pressing the wheel.

Each parameter function can be edited by pressing the tuning wheel (ENTER). By tuning the wheel you can position the cursor to the desired selection. By pressing the tuning wheel (ENTER) you switch to the Edit-mode. The text- and/or number positions can be individually selected by tuning the wheel. Pressing the wheel (ENTER) confirms your input and switches back to the selection mode. After a complete and correct adjustment you have to position the cursor right to the symbol ↵ ENTER and confirm it by pressing the tuning wheel. The display switches back to the selection mode of the parameter display!

**5.4 Rear view**

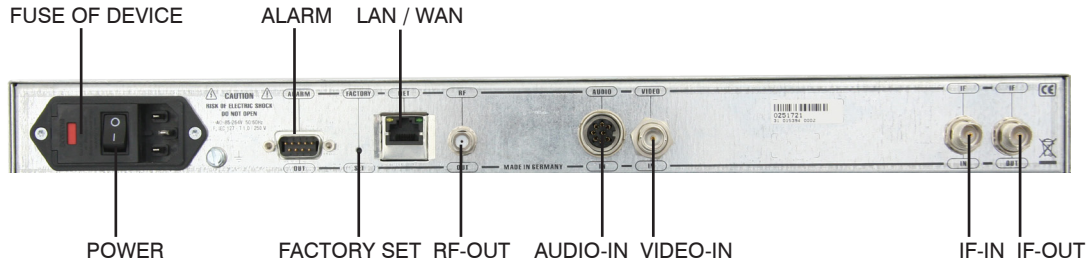

**5.5 9-pin D-SUB connector configuration (alarm contact)**

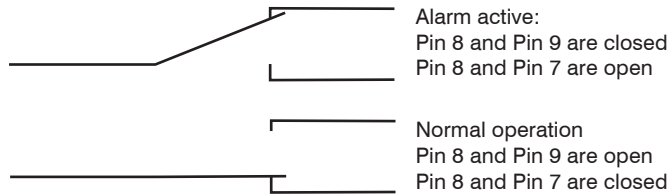
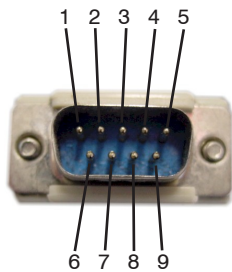

**5.6 Audio socket**

**Pin assignment**

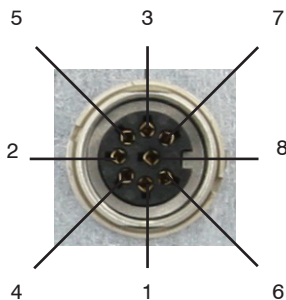

- 1 stereo left+ / dual A+ / mono+
- 2 screening / earth
- 3 stereo right+ / dual B+
- 4 stereo left- / dual A- / mono-
- 5 stereo right- / dual B-
- 6 control line contact 1
- 7 control line contact 2
- 8 control line return path (earth)

**External control of the audio mode**

9228.82/ .91/ .92:

- Mono** Pins 6/ 8: Connection open  
Pins 7/ 8: Connection closed
- Stereo** Pins 6/ 8: Connection closed  
Pins 7/ 8: Connection open
- Dual** Pins 6/ 8: Connection closed  
Pins 7/ 8: Connection closed  
or  
Pins 6/ 8: Connection open  
Pins 7/ 8: Connection open

9228.85:

- Mono L** Pins 6/ 8: Connection open  
Pins 7/ 8: Connection closed  
or  
Pins 6/ 8: Connection closed  
Pins 7/ 8: Connection closed  
or  
Pins 6/ 8: Connection open  
Pins 7/ 8: Connection open
- Mono L+R** Pins 6/ 8: Connection closed  
Pins 7/ 8: Connection open

## 5.7 Factory settings

By pressing of the switch "FACTORY SET" at the rear side of the device all settings stored in the EEPROM will be deleted and replaced by the default settings. The device will go back to these default values. The default settings are listed in chapter 8 (Menu structure of display handling).

## 6. Programming by web server

### 6.1 Network connection to computer



#### System requirements:

- PC/ laptop with 10/100 Mbit Ethernet interface
- Internet browser (e.g. Windows Internet Explorer), which accept JAVA-Script.

#### Setup the connection:

The VMA 191 must be connected to PC Network using an Ethernet cable. The IP address of the VMA 191 control port is 192.168.2.80 on delivery. The address of the network connection at the computer must be adapted to the IP address of the VMA 191 (subnet mask: 255.255.255.0, IP address: 192.168.2.XXX). Don't be use the same combination lock for XXX like the IP address of the VMA 191. The IP address of the VMA 19x is entered onto the browser interface.

When the link up has been successfully made, the device starts with the device status page.

The language (english/ german) can be selected on the right side of each page. To change the settings of the device at the first user log-in window will be open automatically.

The access to the configuration menu is password protected. Access data (factory settings):

Registration details	Valid string
User name	user
Password	password

After successful log-in the parameters can be modified.

The user log-in is only temporarily. The connection has to be refreshed after some time.

## 6.2 Device status



Choose language

german, english

### Device settings

Identifier

e.g. programme name acc. adjustments in 6.3

Frequency

acc. adjustments in 6.3

Level

acc. adjustments in 6.3

Level monitoring

acc. adjustments in 6.3

Tolerable level variation

acc. adjustments in 6.3

RF-Signal

on/ off acc. adjustments in 6.3

### Information

Video input

display **SYNC** pulse or **noSYNC** pulse at the video input

Up Converter

status of up converter, not ok → device faulty

RF-Amplifier

status of RF-Amplifier, not ok → device faulty

VPS Data

display of reading VPS data: date, time, nation code + address range, sound data + special identification

Date

acc. adjustments in 6.3

Time

acc. adjustments in 6.3,

12/ 24-h-mode selectable

Device number

display of the device number

Device index

display of the device index (hardware)

Temperature

temperature of device, °C/ °F selectable

## 6.3 Standard settings



Choose language

german, english

### Identifier

Name

independent text field for device identification (max. 30 characters)

### Output

Channel

channel selection (2 ... 69, standard B/G, R1 ... 69, standard D/K, 2 ... 134, standard M)

Level

adjustment range: -10 ... +14 dBm

RF-Signal

selection: on/ off

Level monitoring

selection: on/ off

Tolerable level variation

selection: ± 1 dB ... ± 5 dB, 0.5 dB steps

### IF-Loop

Input/ Output

selection: Activated/ Deactivated

Input frequency

selection: 36.000, 36.125, 36.150, 38.900, 44.000, 45.750 MHz

Output frequency

38.900 MHz

### SNMP

SNMP trap message

on/ off

### Date/ Time

Date

input format: dd.mm.yy

Time

input format: hh:mm (AM/ PM)

Date/Time input must be set to initialize internal clock (after first start-up of device or reinitializing after a longer shut-down). Additional selection of AM/PM in 12-h-mode.

### 6.4 Extended settings



Choose language

german, english

**Input**

Audio impedance  
Audio signal  
Audio level  
Audio mode

selection: 600/ 12000 Ohm  
selection: balanced/ unbalanced  
adjustment range: -6 ... 9 dBu  
selection: auto (VPS), extern, mono, stereo, dual (if sound carrier 2 on)  
auto (VPS), extern, monoL, monoL+R (if sound carrier 2 off)

Video low pass  
Video clamping  
Video AGC

selection: On/ Off  
selection: soft/ hard  
selection: On/ Off

**Output**

Sound deviation  
Sound carrier 2  
Picture carrier frequency

selection: 30 kHz (if sound carrier 2 on)  
30/ 50 kHz (if sound carrier 2 off)  
selection: On/ Off  
adjustment range: 45000 ... 862000 kHz

### 6.5 Software overview



Choose language

german, english

**Software versions:**

**WEB-Frontend**

WEB Server

**System software**

System Controller

Up Converter

RF Amplifier

Display Controller



## 7. SNMP management

### 7.1 Download MIB



Choose language                      german/english

The complete MIB for an VMA 191 can be downloaded like described under "Instructions" on this web-site and clicking the "MIB Download"-link. With the aid of an MIB browser, the relevant MIB can be decided upon and taken over to control the device via a SNMP manager and/or an network manager capable of SNMPv2c.

### 7.2 Trap messages

Item	Message	Message Type	Explanation
01	System Reset	WARNING	reset by internal error
02	Signal ok	INFORMATION	module works correctly
03	Input not sync	WARNING	no signal at the video or IF input
04	IIC error	CRITICAL	IIC bus error
05	Internal controller reset	WARNING	error when accessing internal controller
06	No response to OPEN command	CRITICAL	error of an internal port
07	Up Converter: PLL1 not locked	CRITICAL	no funktion at the PLL 1 converter
08	Up Converter: PLL2 not locked	CRITICAL	no funktion at the PLL 2 converter
09	Up Converter: IF input too small	WARNING	IF level at Up converter input too small
10	Up Converter: IF input too large	WARNING	IF level at Up converter input too large
11	UP Converter: IF input ok	INFORMATION	IF level at Up converter input ok
12	Amplifier: RF Level too large	WARNING	RF level at amplifier too large
13	Amplifier: RF Level too small	WARNING	RF level at amplifier too small
14	Amplifier: RF Level ok	INFORMATION	RF level at amplifier ok
15	Input sync	INFORMATION	signal at video input ok

## 8. Menu structure of display handling

The following settings are the default settings. After a reset by pressig of „FACTORY SET“ on the rear side of the device all settings stored in the EEPROM will be deleted and replaced by these defaults and the device will go back to these settings (see chapter 5.7).

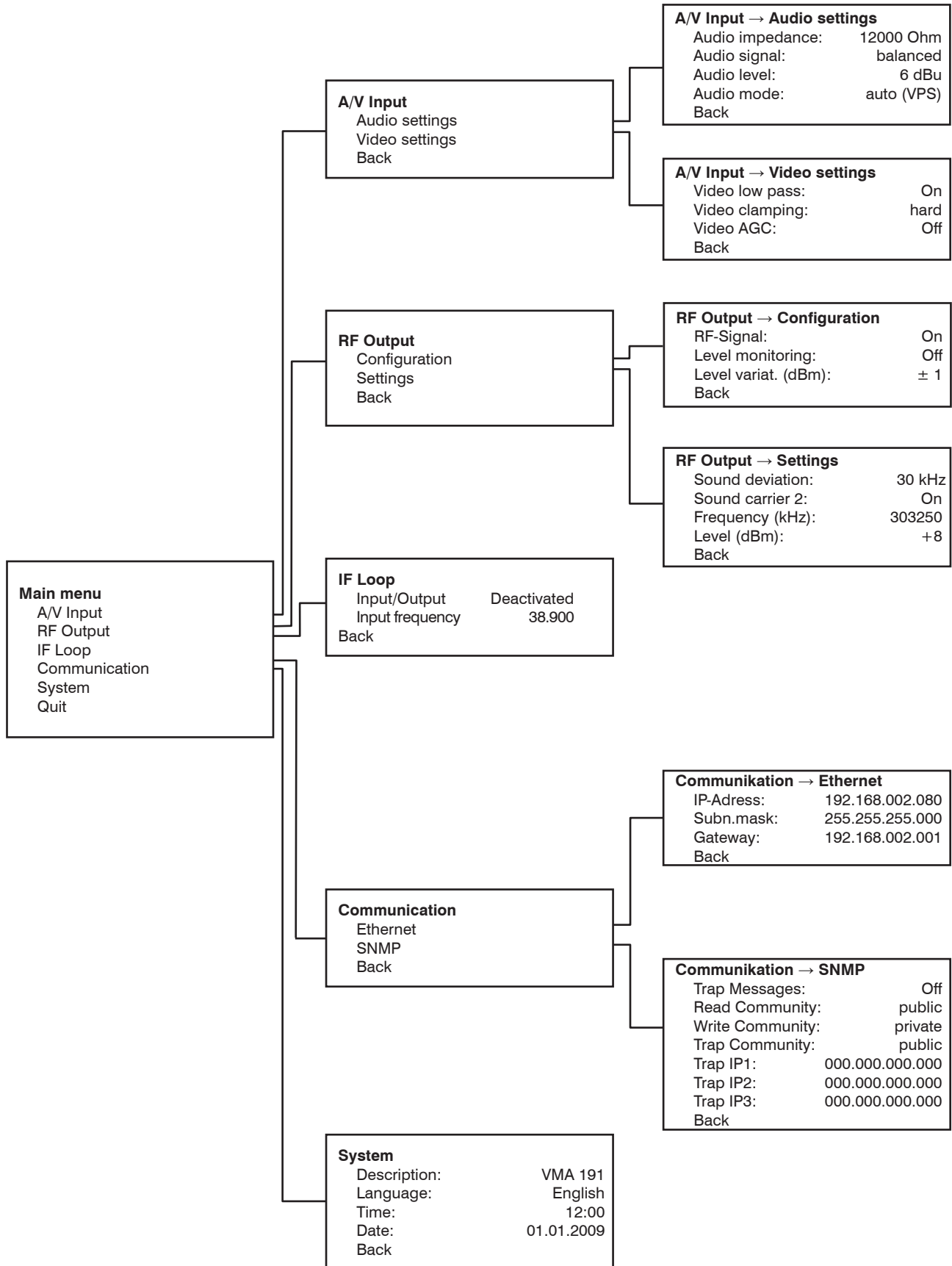

## 9. Block diagram

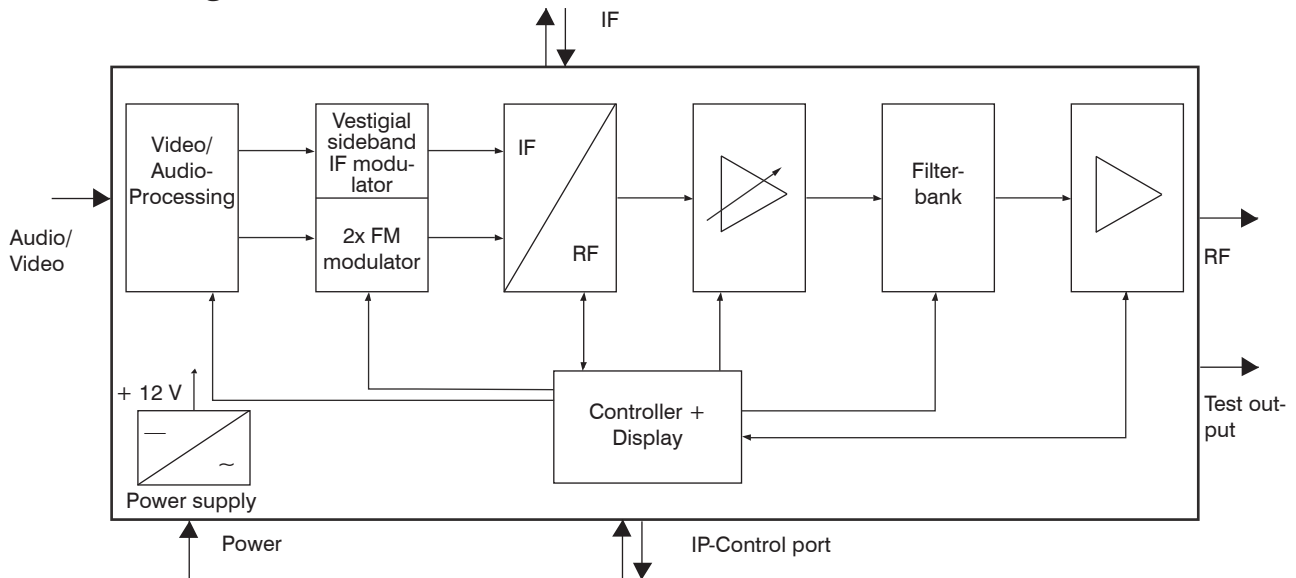

## 10. Technical data

### Video input

Input voltage with AGC	0,8 ... 1,3 V <sub>pp</sub>
without AGC	1 V
Impedance	75 Ω
Connector	BNC socket
Input filter (disconnectable)	5 MHz low pass
Clamping (switchable)	soft/ hard
AGC	disconnectable

### Audio input

Input level	-6 ... +9 dBu
Input resistance (switchable)	0.6/ 12 kΩ
Connector	8-poles according to DIN 45326 (IEC 130-9-20)
Configuration (switchable)	balanced/ unbalanced

### IF loop

Output/ input	internal jumpered or external available (switchable)
Output frequency	38.900 MHz
Input frequency	36.000, 36.125, 36.150, 38.900, 44.000, 45.750 MHz
Output/ input level	- 14 dBm (95 dBμV)
Connector	2 x BNC socket, 75 Ω
IF decoupling	≥ 80 dB

### RF output

9228.82	
TV standard	B/G
Sound carrier frequencies	5.5/ 5.742 MHz above pic. carrier
9228.91:	
TV standard	D/K
Sound carrier frequencies	6.5/ 6.25 MHz above pic. carrier
9228.92:	
TV standard	D/K
Sound carrier frequencies	6.5/ 5.742 MHz above pic. carrier
9228.85:	
TV standard	M
Sound carrier frequencies	4.5 MHz
9228.82/ .91/.92:	
Sound procedure	FM dual carrier processing
Sound operation modes	mono/ stereo/ dual/ auto (VPS controlled)/ external
Sound dev. 1 mono carrier	30/ 50 kHz
Sound dev. 2 mono carrier	30 kHz
Sound dev. dual tone	30 kHz
9228.85:	
Sound procedure	FM one carrier processing

### Sound operation modes

mono/ summing left-right/ auto (VPS controlled)/ external

Frequency deviation	± 25 kHz
Output frequency range	45 ... 862 MHz
Tuning step	10 kHz/ 25 kHz*
Max. output level	14 dBm (123 dBμV)
Level adjustment range	-10 ... +14 dBm
Channel allocation	adjacent channel ability
Connector	F socket, 75 Ω
Return loss	≥ 18 dB 45 MHz
Test output	- 1.5 dB/ Octave - 30 dB (± 1 dB)

### Signal quality

Single channel intermodul.	≥ 66 dB
Noise level 3rd order	≥ 60 dB
Spurious 45 ... 862 MHz	≥ 60 dB
C/N within channel (BW = 4,8 or 4,2 MHz in 9228.85)	typ. 69 dB
C/N (> 25 MHz space from channel center; BW = 4,8 or 4,2 MHz in 9228.85)	typ. 80 dB
Parallel sound noise ratio unweighted/ weighted	typ. 68/ 59 dB
Max. frequency stability	± 30 kHz
Output level stability	± 0.5 dB (5 .. 45 °C)
Output level accuracy	± 1.5 dB
Amplitude frequency response channel (8 MHz)	max. 1 dB <sub>pp</sub>

### Operation parameters

Voltage / current	100 ... 240 V ~ 50/60Hz
Power consumption	100 ... 353 V = 18 W

### Environmental conditions

Temperature range	-10 ... +55 °C
Temperature range (for data keeping)	5 ... 45 °C
Relative humidity	≤ 80 % (non condensing)
Mounting location	splash-proof and drip-proof

### Delivery content

Dimensions (w x h x d)	448 x 44 x 350 mm
Weight	4,200 g

\* 25-kHz-step only with active IF loop and 36.125 MHz input frequency

## 11. Glossary

AGC	Automatic Gain Control
AM	Amplitude modulation
ATV	Analogue Television
AV	Audio/Video
BW	Bandwidth
C/N	Carrier to Noise ratio
EMC	Electromagnetic Compatibility
FM	Frequency modulation
HTML	Hypertext Markup Language
HTTP	Hypertext Transfer Protocol
IF	Intermediate Frequency
IFI	Intermediate Frequency Interface
IIC	Inter-Integrated Circuit (I <sup>2</sup> C bus, device internal data bus)
IP	Internet Protocol
LAN	Local Area Network
LED	Light Emitting Diode
MAC	Media Access Control
MIB	Management Information Base
RF	Radio Frequency
SNMP	Simple Network Management Protocol
TV	Television
VPS	Video Programming System
WAN	Wide Area Network

## 12. Bibliography

- [1] EN 60728-11: Cable networks for television signals, sound signals and interactive services Part 11: Safety (IEC 60728-11:2005); German version EN 60728-11:2005
- [2] RFC 1157 Request for Comments (RFC): RFC Database URL: [Http://www.rfc-editor.org/rfc.html](http://www.rfc-editor.org/rfc.html)
- [3] EN 50083-2 : Cabled distribution systems for television and sound signals. Electromagnetic compatibility for equipment; EN 50083-2:2001

## 13. Document history

Version	Date	Modification	Author
1.00	13.08.2009	basic document	Häußer

Options and other TV standards available upon request! Subjects to changes due to technical progress.

# Declaration of Conformity

## The Manufacturer

BLANKOM Antennentechnik GmbH · Hermann-Petersilge-Str. 1 · 07422 Bad Blankenburg · Germany

herewith declares the conformity of the product group

**Product name:** Audio/ Video Modulator

**Type:** VMA 191

**Product number:** 9228.8x, 9228.9x

according to the following regulations

EN 50083-2

EN 60728-11 (as far as relevant)

and additional device-specific regulations, enclosed above, which these products are subjected to.

**Date:** 13.08.2009

**Signature:**



Piero Kirchner  
(Managing Director)