

TTC 501

TWIN TERR. TV - TRANSMODULATOR

DVB - T (COFDM) CI ATV(AM)

Standard B/G, D/K, I, L, M

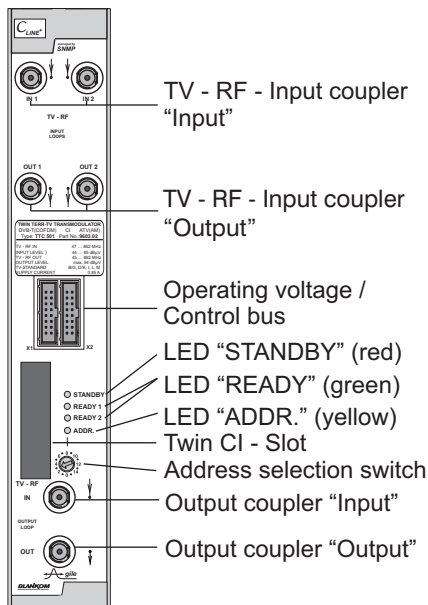

Pic. 01

DEVICE VARIANTS

TTC 501 9603.02 DVB-T analogue TV [45 ... 862 MHz]

Minimum software requirements for HCB 100 (Headend Controller)

9650.03: Version 2.34
9650.04/.05: Version 3.18

GENERAL

The TWIN terrest. TV-Transmodulator TTC 501 a module of the C-LINE⁺ headend system, this system is optimal for small and medium community networks. The TTC 501 is distinguished by the unique ITT – Independent Twin Technology. The TTC 501 converts 2 TV programs from DVB-T channels into 2 analogue Cable-TV channels. The module can be programmed and adjusted via a central control unit Headend Controller HCB 100 manually or remotely and operate after programming autarkic. The status of the module is displayed via colored LEDs:

| | | |
|--------|-------------|------------------------------|
| Red | - STANDBY | Standby mode |
| Green | - READY 1,2 | Operating mode / Channel 1,2 |
| Yellow | - ADDR. | Remote access |

FUNCTION DESCRIPTION

The module converts 2 services from DVB-T channels into 2 analogue CATV channels. The tuner selects the DVB-T channel, afterwards the conversion follows into the I/Q baseband. The transportstream will be fed directly to the DVB module or via the Common interface.* The DVB – module consists of the demultiplexer and the MPEG decoder. The DVB module generates an analogue Video- and Audio signal. The TTC 501 supports services like Teletext, VPS, WSS, optional test lines and the flash of subtitles. The analogue signals feed the IF modulators. After IF filtering follows the conversion into the wanted output channels. Two independent adjustable channels (output frequency and level) are available at the output. In and outputs are performed in loop-through technology therefore distribution and combining are realized within the module.

* The design of the CI interface of this module is done according to DVB compliant standards. According to the dependencies in interaction of DVB signals, CA-modules and smartcard we can not assure a general functional reliability for all application possibilities. Please contact our Service-Department for further assistance!

ADJUSTMENT POSSIBILITIES

Adjustment with the Headend Controller

Adjustment of the addresses at the Bus Extender BEB 100 and at the modules
Activation of the programming mode of the individual modules by selecting the line (BEB 100) and the module position (01 - 15) at the Headend Controller (HCB 100)
yellow LED is lit up til the beginning of the parameter adjustment
Adjustment of the TTC 501 parameter (see Pic. 02) green LED is lit up
After the programming, the TTC 501 will be automatically switched into the operating status
yellow LED light up briefly / green LED is lit up

Adjustment with PC / Laptop

Condition for the remote programming is an "online - connection" after IP - standard and an ethernet connection at the PC / Laptop
Adjustment of the line / position addresses at the Bus Extender BEB 100 as well as at the modules
At the Headend Controller HCB 100 IP - address input (e.g. 192.168.001.001)
For "direct connection" between a PC and HCB 100 use a crossed patch cable (RJ 45)
For connection over a deviation use an uncrossed patch cable
HTML - browser start-up and put in IP - address as target address
If connected correctly the HTML - control surface at the PC will open up and a blue LED (LINK) at the HCB 100 will be lit up
All adjustment of the modules are specified at the control surface

The manual instructions of the Headend Controller HCB 100 and the Bus Extender BEB 100 have to be considered!

TECHNICAL DATAS

VHF/UHF - Input

Frequency range 47...862 MHz
 Frequency grid 166.666 kHz, 62.5 kHz
 AFC - Range 500 kHz, 125 kHz
 Input level *) 44 ... 85 dB μ V

*) typ. min at 64-QAM,
 CR=2/3, GI=1/32,
 BER=2*10⁻⁴, Gaussian
 Channel

Minimum Input level

(GI=1/32, BER=2*10⁻⁴, Gaussian Channel, typical)

Code rate QPSK / 16-QAM / 64-QAM
 1/2 30 / 36 / 41 dB μ V
 2/3 32 / 38 / 44 dB μ V
 3/4 33 / 39 / 45 dB μ V
 5/6 34 / 40 / 46 dB μ V
 7/8 35 / 41 / 47 dB μ V

Connectors

Impedance 75
 Through loss 1.5 dB

COFDM - Demodulator / Decoder

Carrier mode 2k, 8k
 Code rate 1/2, 2/3, 3/4, 5/6, 7/8
 Protection class 1/4, 1/8, 1/16, 1/32
 Modulation QPSK, 16 QAM, 64 QAM
 Signal processing EN 300744 (DVB-T)

Decryption - Interface

1 Common Interface per channel PCMCIA - Slot
 according to EN 50221
 5 V

Operating voltage

TV - Output

TV - Standards B/G, D/K, I, L, M
 Sound procedure (B/G, D/K) FM - dual carrier
 Sound (B/G, D/K) mono / stereo / dual / auto
 Sound (I, L, M) mono
 Max. output level 94 dB μ V
 Level adjustment range 20 dB (0.5 dB - steps)
 Impedance 75

Connector F - socket
 Through loss 1.5 dB
 Output frequency range 45 ... 862 MHz
 Tuning grid 125 kHz

Operating parameter

Voltage / current 12 V (0,2 V) / 850 mA
 (without CA modul)
 Residual ripple of the supply voltage 10 mV_{pp}

Environmental conditions

Temperature range -10 ... +55 °C
 Relative humidity 80 % (not condens.)
 Mounting vertically
 Mounting location squirting and dripping
 water protected

Physical information

Dimensions (W x H x L)
 without 19" - Adapter 50 x 276 x 148 mm
 with 19" - Adapter 50 x 301 x 148 mm
 Weight 1130 g

Delivery content

1 x BUS - connector
 3 x F - connection cable 140 mm
 1 x Programming

HEADEND BUS STRUCTURE

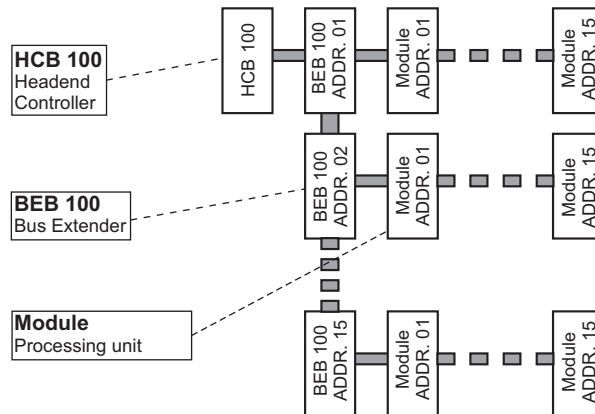

The number of the possible module connections (00 ... 15) to a BEB 100 depends on the total power consumption of this line!

Pic. 02

SECURITY AND OPERATING INSTRUCTIONS

STOP When assembling, starting-up and adjusting the modules, it is necessary to consider the system specific references in the manual instruction!

⚠ The modules may only be installed and started up by authorized technical personnel!

⚠ When assembling the modules into the receiving points, the adherence of the EMC regulations is to be secured!

⚠ The assembly and wiring have to be done without voltage!

⚠ All active modules may only be operated with the Headend Controller HCB 100 or Bus Extender BEB 100!

⚠ The main voltage and the operating voltage of the modules working by DC have to be in compliance to the operating parameters described in the technical datas.

⚠ With all work the defaults of the DIN EN 50083 have to be considered! Especially the safety relevant execution of the DIN EN 50083/1 is necessary!

Options and other TV standards available upon request!

Changes due to technical progress possible.

Part n°: 9603.02

BLANKOM Antennentechnik GmbH

Hermann - Petersilge - Str. 1 07422 Bad Blankenburg Germany Phone +49 (0) 36741/ 60-0 Fax +49 (0) 36741/ 60-100

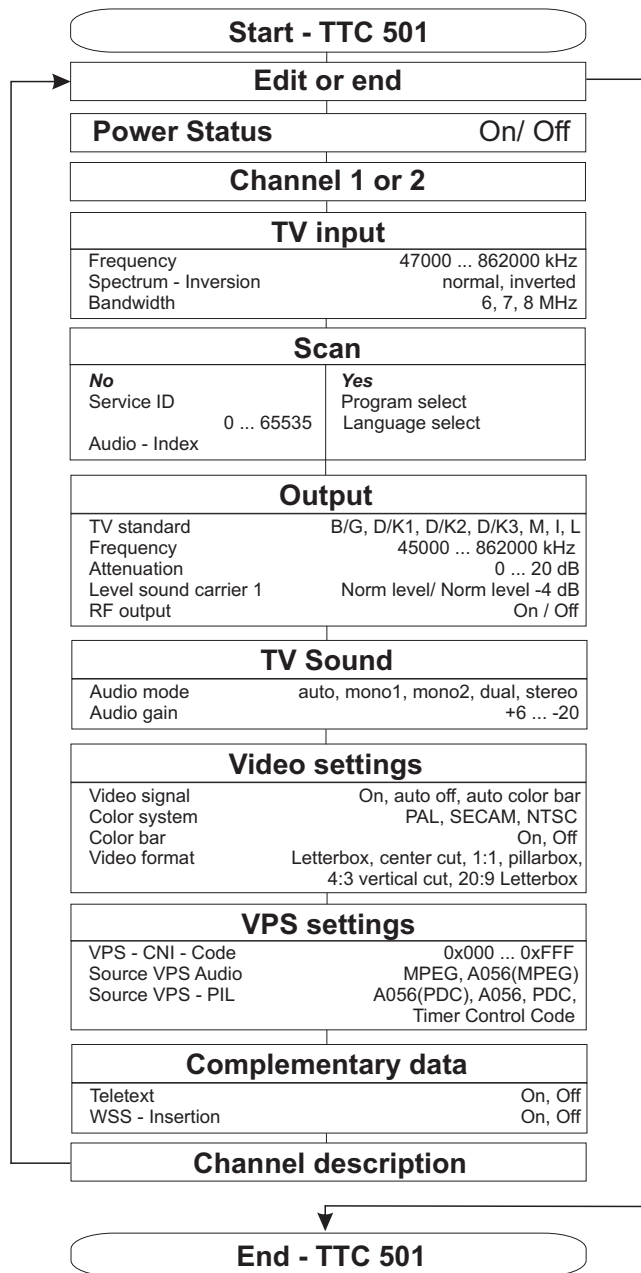

Pic. 03