

Operating instructions

TWIN 8PSK/QPSK TRANSCODER

DVB-S/ S2 /DCII (8PSK, QPSK) DVB-C/ J.83 Annex B (QAM)









Contents

1. Safety and operating instructions	1
2. Front view.	2
3. Device variants.	2
4. General	2
5. Function description.....	2
6. Adjustments.....	2
6.1 Adjustment with the Headend Controller	2
6.2 Adjustment with PC/Laptop	2
7. Meaning of LED signals	3
8. Programming by webservers.....	4
8.1 Main menu.....	4
8.2 Extended settings	5
8.3 NIT entries	5
8.4 Software overview	6
8.5 Device status	6
8.6 Factory settings	6
9. Menu control with Headend Controller	7
10. Trap messages	7
11. Block diagram	8
12. Head end bus structure	8
13. Example of use.....	9
14. Technical data	9
15. Glossary	10
16. Bibliography	10
17. History	10



STC 096
Part No: 9619.08

1. Safety and operating instructions

-  When assembling, starting-up and adjusting the modules, it is necessary to consider the system specific references in the manual instruction!
-  The modules may only be installed and started up by authorized technical personnel!
-  When assembling the modules into the receiving points, the adherence of the EMC regulations is to be secured!
-  The assembly and wiring have to be done without voltage!
-  All active modules may only be operated with the Headend Controller HCB 100 or Bus Extender BEB 100!
-  The main voltage and the operating voltage of the modules working by DC have to be in compliance to the operating parameters described in the technical data.
-  With all work the defaults of the DIN EN 50083 have to be considered! Especially the safety relevant execution of the DIN EN 50083/1 [4] is necessary!

2. Front view

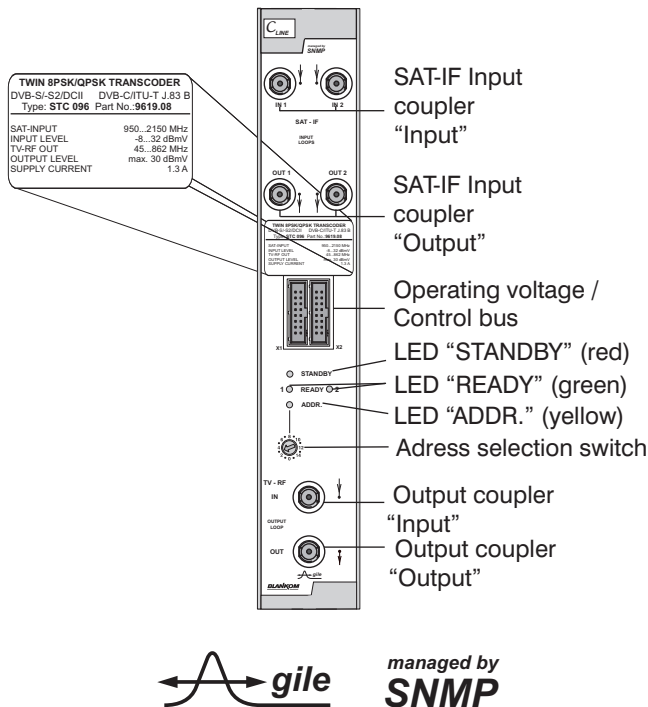

3. Device variant

STC 096 9619.08 8PSK, QPSK QAM/HF [45 ... 862 MHz]

Minimum software requirements for HCB 100:

9650.03: Version 2.34*
 9650.04/05: Version 3.18*

* Updates: www.blankom.de

4. General

The TWIN 8PSK/QPSK - Transcoder STC 096 is one component of the C-LINE head end system. The module converts two digital transponders of DVB-S/S2 or DCII into the digital cable standard DVB-C or ITU-T J.83 Annex B (QAM). The signals will be transmodulated from the SAT-IF range into cable-TV-channels. Service information of the SI-Tables NIT and CAT which are forwarded with the MPEG - transport stream can be read and processed. The output signals allocate an adjacent channel within cable-TV range and one space channel is also possible. The NIT can be controlled and generated automatically as well as distributed/forwarded to further transmodulators via the Headend Controller (HCB100). The operator ID's of the CAT can also be edited via the operation software. The PID - filter enables blocking of up to 6 audio- and/or video data streams. The management of the modules will be done via the central control unit (Headend Controller / HCB 100) manually or remotely.

5. Function Description

The module contains two transmodulators (1 per channel) which are designed identically until the IF - range. A DVB-S/S2 or DCII transponder will be selected by the tuner and will be demodulated to the MPEG data stream afterwards. The processing of the transport stream will be done. The conversion into the IF range is done within the following modulator (QAM). The subsequent conversion into an adjacent channel pair within the cable-TV range is done for both channels together. The programming of the output channels is done via transmodulator 2. Transmodulator 1 is normally one channel lower (with spare space two channels lower). The channel spacing within the TV - ranges will be considered automatically. Offset - frequencies can be programmed, too. In- and outputs are performed in loopthrough technique. A voltage of 12 V is permanently available at the SAT - inputs for the remote supply of the LNB.

Special functions: Test signal (according adjustments of symbol rate and QAM constellation)
 Carrier signal - Generator (Signal level measurement)

6. Adjustments

Adjustment with the Headend Controller

Adjustment of the addresses at the Bus Extender BEB 100 and at the modules
 Activation of the programming mode of each module by selecting the line (BEB 100) and the module position (01... 15) at the Headend Controller (HCB 100)
 yellow LED will be lit up til the beginning of the parameter adjustment
 Adjustment of the STC 096 parameter (see chapter 9)
 green LED is lit up
 After the programming the STC 096 will be automatically switched into the operating status
 yellow LED lights up briefly / green LED is lit up

Adjustment with the PC / Laptop

Condition for the remote programming is an "online - connection"
 after IP - standard and an ethernet connection at the PC / Laptop
 Adjustment of the line / position addresses at the Bus Extender BEB 100 as well as at the modules
 At the Headend Controller HCB 100 IP - address input (e.g. 192.168.001.001)
 For "direct connection" between a PC and HCB 100 use a crossed patch cable (RJ 45)
 For connection over a deviation use an uncrossed patch cable
 HTML - browser start-up and put in IP - address as target address
 If connected correctly the HTML - control surface at the PC will open up and a blue LED (LINK) at the HCB 100 will be lit up
 All adjustment of the modules are specified at the control surface

The manual instructions of the Headend Controller HCB 100 and the Bus Extender BEB 100 have to be considered!

STC 096

Part No: 9619.08

TWIN 8PSK/QPSK TRANSCODER

DVB-S/ S2 /DCII (8PSK, QPSK) DVB-C/ J.83 Annex B (QAM)

**7. LED's on front panel**

Colour	Status	Meaning of display
Red (STANDBY)	Permanently illuminated	Module is on standby
	Flashing	Module faulty (hardware)
Green (READY 1,2)	Permanently illuminated	Module working, everything ok
	Flashing	Dysfunction depending in signal: Tuner not sync (e.g. in case of missing input signal) no input on the QAM modulator buffer overflow in the QAM modulator QAM overflow (input data rate on the QAM modulator too large)
Yellow (ADDR)	Illuminated or flashing	Remote control, making contact / data transmission

8. Programming by web server *

8.1 Main menu

TWIN 8PSK/QPSK TRANSCODER, STC 096 (9619.08 / 00), Address 03 / 05			
Channel	1	2	
Description	xxxx	xxxx	
Input			
SAT-ZF	1236	1354	MHz
Symbolrate	27500	27500	kSps
FEC	DVB-S 3/4 (QPSK)	DVB-S 3/4 (QPSK)	
Status	SYNC	SYNC	
Output			
Output channel	S21 (306.00 MHz)	S22 (314.00 MHz)	
Output frequency	306000	314000	kHz
QAM Symbolrate	6900	6900	kSps
Modulations	64	64	QAM
RF-Signal	On	On	
Status			
QAM modulator	Transcoder	Transcoder	
NIT treatment	Off	Off	
CAT treatment	Off	Off	
Cable DSL	Off	Off	
manual TS data	Off	Off	
PID filter	Off	Off	
Channel 1+2			
Encoder Mode	DVB-C		
Output attenuation	0		dB
Output level	90		dB μ V
Operating status	On		[On]
Transmit trap	On		
<input type="button" value="Extended settings"/> <input type="button" value="NIT entries"/>			
<input type="button" value="Software version"/> <input type="button" value="Status"/>			
<input type="button" value="Default"/>			
<input type="button" value="Update"/> <input type="button" value="Transmit"/>			
<input type="button" value="<<<<"/> <input type="button" value="Back"/> <input type="button" value=">>>>"/>			

Name of device, item number, address in head end

Description program name (max. 30 characters)

Input

SAT-IF adjustment range 950 ... 2150 MHz
 Symbol rate adjustment range 1000 ... 45000 kSps
 FEC auto or selection see chapter 9
 Status displays, if **SYNC**hronisation or **noSYNC**hronisation exists at the input

Output

Output channel channel selection (channel 2 ... 69 DVB-C or channel 2...116 Annex B)
 Output frequency dedicated output frequency
 QAM symbol rate selection: 6900, 6875, 6111, 6000, 3450, 1750 kSps
 Modulations selection: 16, 32, 64, 128, 256 QAM
 RF Signal selection: On/Off

Status

QAM modulator according adjustment menu 1
 NIT treatment On/Off according adjustment menu 1
 CAT treatment On/Off according adjustment menu 1
 manual TS data On/Off according adjustment menu 1
 PID filter On/Off according adjustment menu 1

Channel 1+2

Encoder Mode DVB-C/ ITU-T (J.83) according adjustment menu 1
 Output attenuation adjustment range 0 ... 20 dB (0.5 dB steps)
 Output level dedicated output level
 Operating status On/Off
 Transmit trap On/Off, if SNMP option in HCB100 enabled, otherwise "locked" display

Routing to the appropriate adjustment menu

Extended settings see menu 1
 NIT entries see menu 2
 Software overview see menu 3
 Status see menu 4
 Factory settings see menu 5

* Further details on this are to be found in the HCB manual

8.2 Extended Settings (menu 1)

TWIN 8PSK/QPSK TRANSCODER, STC 096 (9619.08 / 00), Address 03 / 05			
Channel	1	2	
Output			
Output frequency	514000	522000	kHz
QAM Symbolrate	6900	6900	kSps
Spectrum	normal	normal	
QAM modulator	Transcoder	Transcoder	
Encoder Mode	DVB-C		
NIT treatment	Off	Off	
Network name	none		
Network ID	0		dez
CAT treatment	Off	Off	
Ca system ID	0		dez
Operator ID	0		dez
Cable DSL	Off	Off	
Network carrier ID	0	0	dez
Net ID	0	0	dez
manual TS data	Off	Off	
Original TS-ID	0	0	dez
Original Network ID	0	0	dez
PID elimination filter			
	Filter / PID	Filter / PID	
PID 1	Off 0	Off 0	dez
PID 2	Off 0	Off 0	dez
PID 3	Off 0	Off 0	dez
PID 4	Off 0	Off 0	dez
PID 5	Off 0	Off 0	dez
PID 6	Off 0	Off 0	dez
<input type="button" value="Update"/> <input type="button" value="Transmit"/>			
<input type="button" value="Back"/>			

Name of device, item number, address in head end

Output

Output frequency adjustment range 45000 ... 862000 kHz
 QAM - Symbol rate adjustment range 1725 ... 7000 kSps
 Spectrum selection normal/invers
 QAM modulator selection Transcoder/Testlevel/Testsignal
 Encoder Mode selection DVB-C (Annex A), ITU-T/J.83 (Annex B) Channel 1+2

NIT treatment activate or deactivate
 Network name freely selectable (max. 30 characters)
 Network ID freely selectable (0...65535); Channel 1+2

CAT treatment activate or deactivate
 CA system ID freely selectable (0...65535); Channel 1+2
 Operator ID freely selectable (0...65535); Channel 1+2

Cable DSL activate or deactivate
 Network carrier ID freely selectable (0...65535)
 Net ID freely selectable (0...65535)

manual TS data activate or deactivate
 Original TS-ID freely selectable (0...65535)
 Original Network ID freely selectable (0...65535)

PID elimination filter

PID 1 On/Off, freely selectable (0...8191)
 PID 2 On/Off, freely selectable (0...8191)
 PID 3 On/Off, freely selectable (0...8191)
 PID 4 On/Off, freely selectable (0...8191)
 PID 5 On/Off, freely selectable (0...8191)
 PID 6 On/Off, freely selectable (0...8191)

Update refresh screen
 Transmit send changes

8.3 NIT Entries (menu 2)

TWIN 8PSK/QPSK TRANSCODER, STC 096 (9619.08 / 00), Address 03 / 05					
Entry	Original TS-ID	Original Network ID	Output frequency (kHz)	QAM Symbolrate (kSps)	Modulation (QAM)
1	1101	1	306000	6900	64
2	1079	1	314000	6900	64
NIT distribution:dynamic Network name:none Network ID:0					
<input type="button" value="Update"/> <input type="button" value="Back"/>					

Name of device, item number, address in head end

NIT entries with all information available

8.4 Software overview (menu 3)

TWIN 8PSK/QPSK TRANSCODER, STC 096 (9619.08 / 00), Address 03 / 05	
Version	
APL Controller	9619.08-81.01 Steuercontroller Anschluss-LP V1.00 08.12.2008 RN
FPGA Controller	9619.05-88.01 MC FPGA-Controller(1) V4.14 02.10.2007 JR
FPGA	9619.05-87.01 FPGA Transportstream Manager V3.00 30.03.2007 WE
NIM 1	9619.08-88.01 NIM-Controller V1.00 28.08.2008 RN
NIM 2	9619.08-88.01 NIM-Controller V1.00 28.08.2008 RN
<input type="button" value="Back"/>	

Name of device, item number, address in head end

Software version

Controller of the front circuit board

FPGA Controller

FPGA TS manager

Frontend (NIM Controller) 1

Frontend (NIM Controller) 2

8.5 Device status (menu 4)

TWIN 8PSK/QPSK TRANSCODER, STC 096 (9619.08 / 00), Address 03 / 05			
Channel	1	2	
Tuner			
Status	<i>no SYNC</i>	<i>SYNC</i>	
Input frequency	1314	1353	MHz
SNR	---	13,94	dB
Output data rate	---	38.014	kBps
Modulation	DVB-S	DVB-S	
TS Manager			
TS Manager	<i>No input data</i>	<i>SYNC</i>	
QAM Modulator	<i>SYNC</i>	<i>SYNC</i>	
Original TS-ID	1101	1079	
Original Network ID	1	1	
Information			
Temperature APL	39 °C		
Temperature NIM	49 °C	54 °C	
Device number	0000000		
Device index	00		
<input type="button" value="Update"/> <input type="button" value="Back"/>			

Name of device, item number, address in head end

Tuner

Status synchronization status
Input frequency display of the input frequency
SNR display of the signal-to-noise ratio
Output data rate display of the net data rate
Modulation display of the transmission standard

TS Manager synchronization status
QAM Modulator synchronization status

Original TS-ID display of the TS ID
Original Network ID display of the Network ID

Information

Temperature APL temperature of the front circuit board
Temperature NIM temperature of the NIM 1 and 2
Device number display of the device number
Device index display of the device index

8.6 Factory settings (menu 5)

Default

When request this menu item all settings made on the module and saved out on the EEPROM will be deleted and replaced with the default settings. The module will go back to these default values. When the setting process is finished, an automatic return to the main menu will be done.

9. Menu control with Headend Controller (HCB 100)

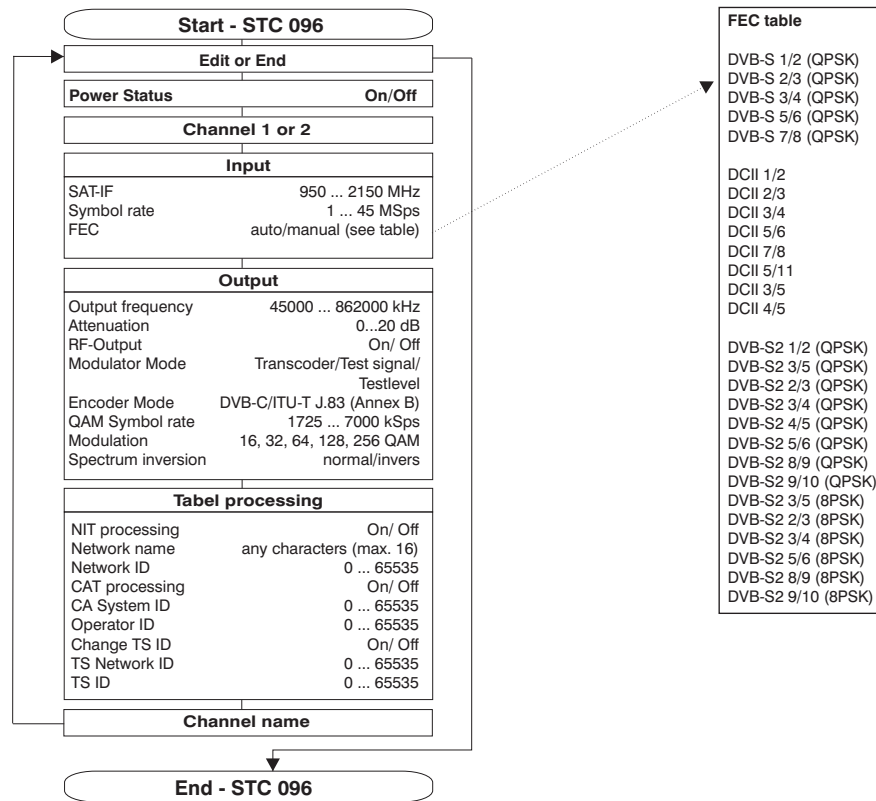

10. Trap-Messages

Pro No.	Message	Typ	Comment
1	Power fail	CRITICAL	short circuit
2	System reset	WARNING	reset by internal error
3	Signal OK	INFORMATION	module networks correctly
4	Tuner not sync	WARNING	no input signal at the tuner
5	IIC error	CRITICAL	IIC-Bus-error
6	TS-FPGA not sync	WARNING	TS-Manager doesn't work correctly
7	QAM Modulator not sync	WARNING	QAM Modulator doesn't work correctly
8	Internal controller reset	WARNING	Internal Controller has been resetted

11. Block diagram

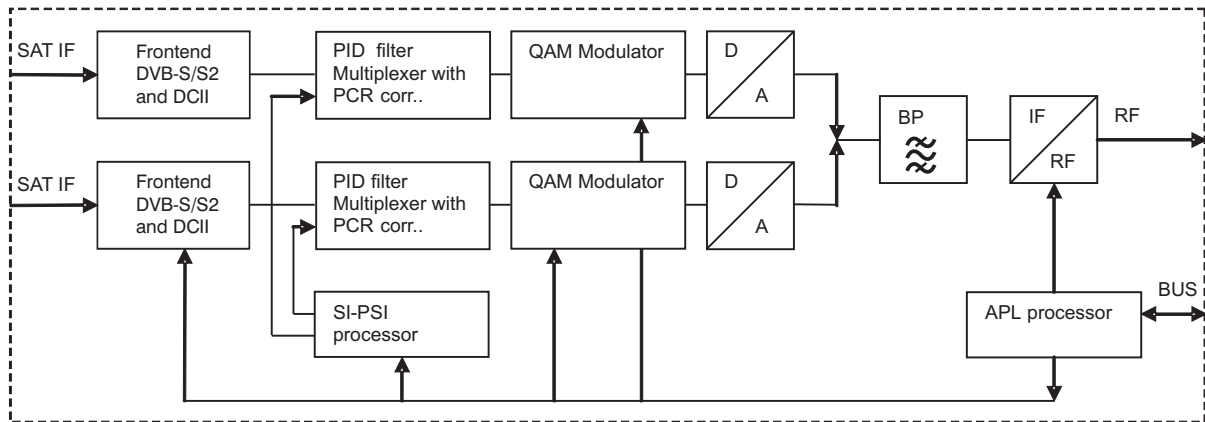

12. Head end bus structure

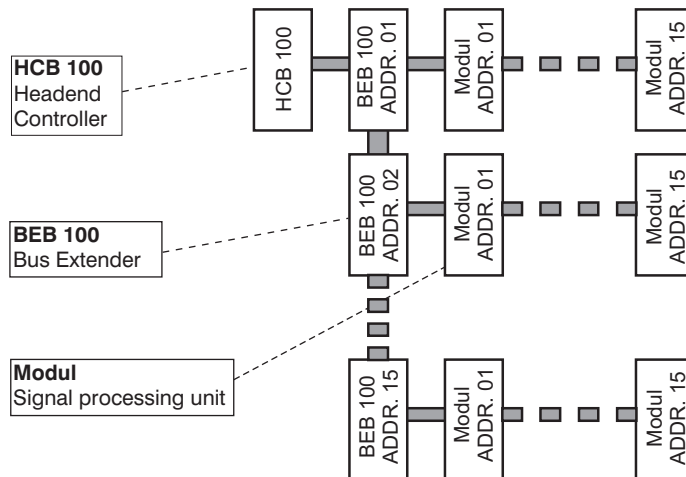

The number of the possible module connections (00 ... 15) to a BEB 100 depends on the total power consumption of this line!

13. Example of use

Integration in existing C-LINE configuration

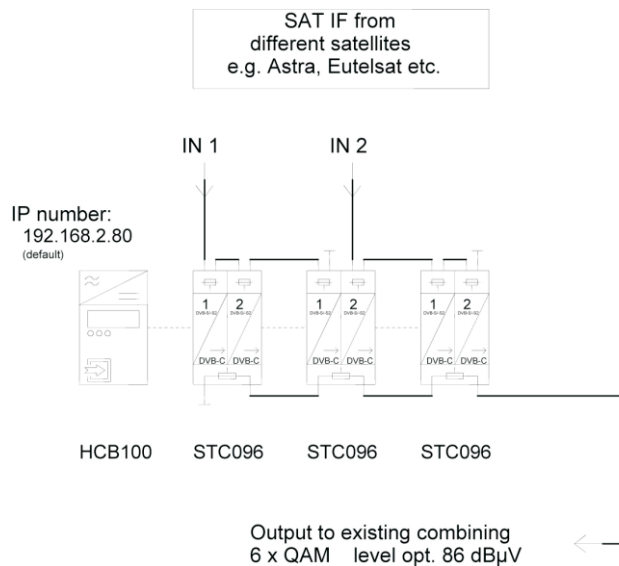

14. Technical data

SAT - IF input

Frequency range	950 ... 2150 MHz
Frequency step	1 MHz
AFC range	± 1 ... 5 MHz (depending on symbol rate)
Connector	F socket
Impedance	75
Through loss	1.0 dB
LNC - remote power supply	12 V / 400 mA

DVB-S demodulator / decoder

Modulation	QPSK
Symbol rate	1 ... 45 MSps
Coderate (Viterbi)	QPSK 1/2, 2/3, 3/4, 5/6, 7/8

DVB-S2 demodulator / decoder

Modulation	QPSK, 8PSK
Symbol rate	5 ... 33 MSps
Code rate (LDPC)	QPSK 1/2, 3/5, 2/3, 3/4, 4/5, 5/6, 8/9, 9/10
	8PSK 3/5, 2/3, 3/4, 5/6, 8/9, 9/10

DCII demodulator / decoder

Modulation	QPSK
Symbol rate	3 ... 30 MSps
Code rate	QPSK 1/2, 3/5, 2/3, 3/4, 4/5, 5/6, 7/8, 5/11

QAM modulator

Symbol rate	1.725 - 7 MSps
QAM modulation	ITU-T J.83 Annex B, DVB-C

QAM constellation	<i>Annex B</i> 64; 256	<i>DVB-C</i> 16; 32; 64; 128; 256
Roll off	12 %, 18 %	15%
Interleaving	Conv. I=128, J=4	Conv. I=12
Forward error connection/FEC	Reed Solomon (128,122) + Trellis	Reed Solomon (204, 188,8)

Modulation error rate	40 dB
Test signal	according adjustment symbol rate & QAM constellation unmod. carrier (signal level)

Measurement signal	unmod. carrier (signal level)
Shoulder attenuation	45 dB
Signal processing	EN 300 429 [3], ITU-T J.83 [5]

Output converter / RF output

Output frequency range	45 ... 862 MHz
Tuning step	250 kHz
Max. output level	90 dBµV
Level adjustment range	0...20 dB (0.5 dB steps)
channel allocation	adjacent channel ability
Impedance	75
Return loss	14 dB
Spurious	55 dB
Connector	F socket
Through loss	1 dB

Operating parameters

Current / voltage	12 V (± 0,2 V) / 1,3 A
Residual ripple of supply voltage	10 mV _{pp}

Enviromental conditions

Temperature range	-10 ... +55 °C
Relative humidity	80 % (non condens.)
Method of mounting	vertical
Location of mounting	splash-proof and drip-proof

Physical Information

Dimension (l x w x h)	
without 19" - adapter	50 x 276 x 148 mm
with 19" - adapter	50 x 301 x 148 mm
Weight	1,400 g

Delivery content

1 x BUS connector
3 x F connecting cable 140 mm

15. Glossary

8PSK	8 Phase Shift Keying
AFC	A utomatic F requency C ontrol
AGC	A utomatic G ain C ontrol
APL	A nschluss p latte (front circuit board)
BER	B it E rror R ate
BW	B andwidth
CA	C onditional A ccess
CAT	C onditional A ccess T able
DCII	D igicipher I I
DVB	D igital V ideo B roadcasting (-C Cable, -S Satellit, -S2 Satellite 2)
EIT	E vent I nformation T able
ETSI	E uropean T elecommunications S tandards I nstitute
FAT	F ile A llocation T able
FEC	F orward E rror C orrection
FPGA	F ield P rogrammable G ate A rray
http	h ypertext t ransfer p rotocol
I/Q	I n-phase/ Q uadrature
ID	I dentifier
IF	I ntermediate F requency
IIC	I nter- I ntegrated C ircuit (internal data bus of the module)
IP	I nternet P rotocol
LDPC	L ow D ensity P arity C heck C ode
LED	L ight E mitting D iode
MAC	M edia A ccess C ontrol
MER	M odulation E rror R atio
MIB	M anagement I nformation B ase
MPEG	M oving P icture E xperts G roup
MPTS	M ulti P rogram T ransport S tream
NIM	N etwork I nterface M odule
Nios	Product name of a processor
NIT	N etwork I nformation T able
PAT	P rogram A ssociation T able
PCR	P rogram C lock R eference
PID	P aket I dentifier
PMT	P rogram M ap T able
PSI	P rogram S ervice I nformation
QAM	Q uadrature A mplitude M odulation
QPSK	Q uadrature P hase S hift K eying
RF	R adio F requency
SDT	S ervice D escription T able
SI	S ervice I nformation
SNMP	S ingle N etwork M anagement P rotocol
SPTS	S ingle P rogram T ransport S tream
TS	T ransport S tream

16. Bibliography

- [1] EN 300 421: Digital Video Broadcasting (DVB): Framing structure, channel coding and modulation for 11/12 GHz satellite services
- [2] ETSI EN 302 307: Digital Video Broadcasting (DVB): Second generation framing structure, channel coding and modulation systems for Broadcasting Interactive Services, News Gathering and other broadband satellite applications
- [3] EN 300 429: Digital Video Broadcasting (DVB): Framing structure, channel coding and modulation for cable systems
- [4] EN 50083-1: Cabled distribution systems for television, sound and interactive multimedia signals, safety requirements
- [5] ITU-T J.83 Digital multi-programme systems for television, sound and data services for cable distribution, Amendment to Annex B (2006)
- [6] RFC 1157 Request for Comments (RFC): RFC Database URL: [Http://www.rfc-editor.org/rfc.html](http://www.rfc-editor.org/rfc.html)

17. History

Version	Date	Modification	Author
1.00	22.01.2009	Basis document	Rudolph

Options and other TV standards available upon request!