

SDB 707

DVB-S/S2 ASI-TS DEMODULATOR
QPSK/8PSK ASI - TS

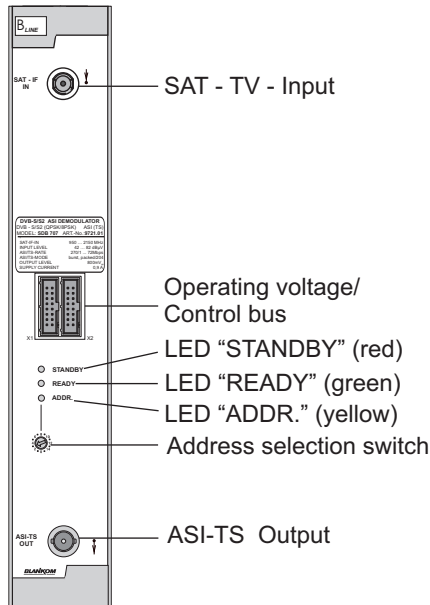

Fig. 01

DEVICE VARIANTS

SDB 707 9721.01 SAT - IF ASI - TS

Minimum software requirements for HCB 100 (Headend Controller)

9650.03: > V 2.24
9650.04: > V 3.00

GENERAL

The SAT - ASI-TS Demodulator SDB 707 is a module of the headend-system B-LINE which is conceived as a complete system for middle sized distribution networks.

The module converts one digital DVB-S/S2 - Transponder into a digital ASI - signal.

The module will be controlled via the central control unit (HCB 100) and is operating independently afterwards.

The status of each device will be displayed via colored LED's:

Red	- STANDBY	Standby mode
Green	- READY	Operating mode
Yellow	- ADDR.	Remote access mode

FUNCTION DESCRIPTION

The digital SAT-IF signal (Transponder) passes through the input amplifier and will then be fed to the tuner. It will be then selected and demodulated into the transport stream level.

The continuous Transport stream will be then embedded directly into the ASI - Data stream (burst und continuous)

Additional functions : Remote supply of LNC

MANUAL PROGRAMING

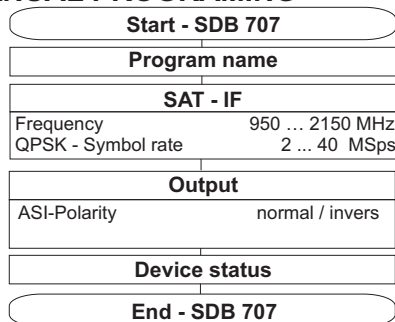

Fig. 02

Adjustment with the headend controller

Adjustment of the addresses at the bus extender BEB 100 and at the modules

Activation of the programming mode of each module by selecting the line (BEB 100) and the module position (01... 15) at the head end controller(HCB 100)

yellow LED will be lit up til the beginning of the parameter adjustment

Adjustment of the SDB 707 parameter(see fig.02)

green LED is lit up

After the programming the SDB 707 will be automatically switched into the operating status

yellow LED lights up briefly / green LED is lit up

Adjustment with the PC / Laptop

Condition for the remote programming is an "online - connection" after IP - standard and an ethernet connection at the PC / Laptop

Adjustment of the line / position addresses at the bus extender BEB 100 as well as at the modules

At the head end controller HCB 100 IP - address input (e.g. 192.168.001.001)

For "direct connection" between a PC and HCB 100 use a crossed patch cable (RJ 45)

For connection over a deviation use an uncrossed patch cable

HTML - browser start-up and put in IP - address as target address

If connected correctly the HTML - control surface at the PC will open up and a green LED (LINK) at the HCB 100 will be lit up

All adjustment of the modules are specified at the control surface

a green LED (LINK) at the HCB 100 will be lit up

All adjustment of the modules are specified at the control surface

The manual instructions of the headend controller HCB 100 and the bus extender BEB 100 have to be considered!

TECHNICAL DATAS

SAT - IF - Input

Frequency range	950 ... 2150 MHz
Frequency grid	1 MHz
AFC - Level	5 MHz
AGC - Level range	42 ... 82 dB μ V
Connector	F - Buchse
Impedance	75
LNC - Remote supply (pluggable)	12 V / 400 mA

DVB-S Demodulator / Decoder

Modulation	QPSK
Symbol rate	1 ... 45 MSps
Coderate (Viterbi)	1/2, 2/3, 3/4, 5/6, 6/7, 7/8
Roll off	35 %
Signal processing	ETS 300 421 (DVB - S)

DVB-S2 Demodulator / Decoder

Modulation	QPSK , 8PSK
Symbol rate	QPSK 1 ... 45 MSps 8PSK 1 ... 30 MSps
Coderate (LDPC)	QPSK 1/4, 1/3, 2/5, 1/2, 3/5, 2/3, 3/4, 4/5, 5/6, 8/9, 9/10 8PSK 3/5, 2/3, 3/4, 5/6, 8/9, 9/10
Roll off	20, 25, 35 %
Signal processing	ETS 302 307 (DVB - S2)

ASI - Output

ASI - Data rate	270 Mbps
ASI - Mode	Continuous
TS - Data rate	continuous according Symbol rate & Coding
TS - Mode	188
Signal processing	EN 50083-9
Output level	800 mV _{ss} (+/- 10%)
Output matching	17 dB
Connector	50 BNC - socket
Impedance	75

Operating parameter

Voltage / Current	12 V (0,2 V) / 400 mA
-------------------	------------------------

Environmental conditions

Temperature range	-10 ... +55 °C
Relative humidity	80 % (not condensing)
Mounting method	Dry, squirting and dripping water protected

Physical information

Dimensions (L x H x W)	without 19" - Adapter with 19" - Adapter
Weight	50 x 276 x 148 mm 50 x 301 x 148 mm 1085 g

Delivery content

1 x BUS - Verbinder

HEADEND BUS - STRUCTURE

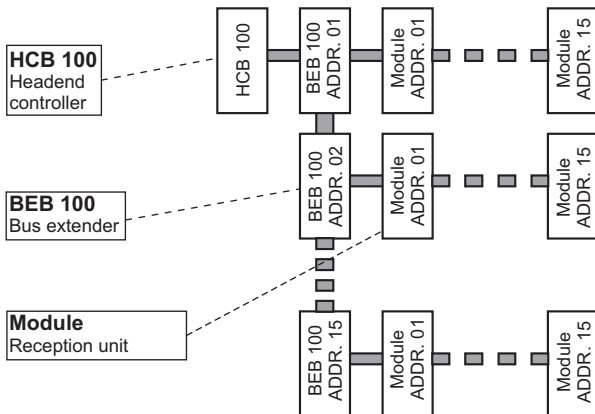

The number of the possible module connections (00 ... 15) to a BEB 100 depends on the total power consumption of this line!

Fig. 03

REMOTE SUPPLY OF LNC

The 12 V - operating voltage of the module is connected at the SAT-IF input socket for the remote supply of the LNC.

NOTIC

The operating voltage of the module has to be disconnected for a short moment after a short circuit at the input socket.

SECURITY AND OPERATING INSTRUCTIONS

STOP When assembling, starting-up and adjusting the modules, it is necessary to consider the system specific references in the manual instruction!

- ⚠** The modules may only be installed and started up by authorized technical personnel!
- ⚠** When assembling the modules into the receiving points, the adherence of the EMV regulations is to be secured!
- ⚠** The assembly and wiring have to be done without voltage!
- ⚠** All active modules may only be operated with the head end controller HCB 100 or bus extender BEB 100!
- ⚠** The main voltage for all power supply units is 230 V, 50 Hz.
- ⚠** With all work the defaults of the DIN EN 50083 have to be considered! Especially the safety relevant execution of the DIN EN 50083/1 is necessary!



Options and other TV standards available upon request!

Changes due to technical progress possible.

Part. - No.: 9721.01

BLANKOM Antennentechnik GmbH

Hermann - Petersilge - Str. 1 07422 Bad Blankenburg Germany Phone +49 (0) 36741/ 60-0 Fax +49 (0) 36741/ 60-100