

Operating instructions

ASI TV Transmodulator

ASI ATV(AM)









Contents

1.	Safety and operating instructions	1
2.	Front view	2
3.	Device variant	2
4.	General	2
5.	Function description	2
6.	Adjustments	2
6.1	Adjustment with the headend controller	2
6.2	Adjustment with the PC / laptop	2
7.	Meaning of LED signals	3
7.1	LED`s for the ASI ports	3
7.2	LED`s on front panel	3
8.	Programming from the Web server	4
8.1	Main menu	4
8.2	Software option	4
8.3	Loading the programme list	5
8.4	Extended settings	6
8.5	Manual settings	7
8.6	Factory settings	7
8.7	Status of device	8
9.	Manual menu control at the headend controller	9
10.	TRAP messages	9
11.	Block diagram	10
12.	Headend BUS structure	10
13.	Example of use	11
14.	Technical data	11
15.	Glossary	12
16.	Bibliography	12
17.	History	12

» ATB 191
Part N°: 9848.01

1. Safety and operating instructions

-  When assembling, starting-up and adjusting the modules, it is necessary to consider the system specific references in the manual instruction!
-  The modules may only be installed and started up by authorized technical personnel!
-  When assembling the modules into the receiving points, the adherence of the EMC regulations is to be secured!
-  The assembly and wiring have to be done without voltage!
-  All active modules may only be operated with the Headend Controller HCB 100 or Bus Extender BEB 100!
-  The main voltage and the operating voltage of the modules working by DC have to be in compliance to the operating parameters described in the technical data.
-  With all work the defaults of the DIN EN 50083 have to be considered! Especially the safety relevant execution of the DIN EN 50083/1 [2] is necessary!

2. Front view

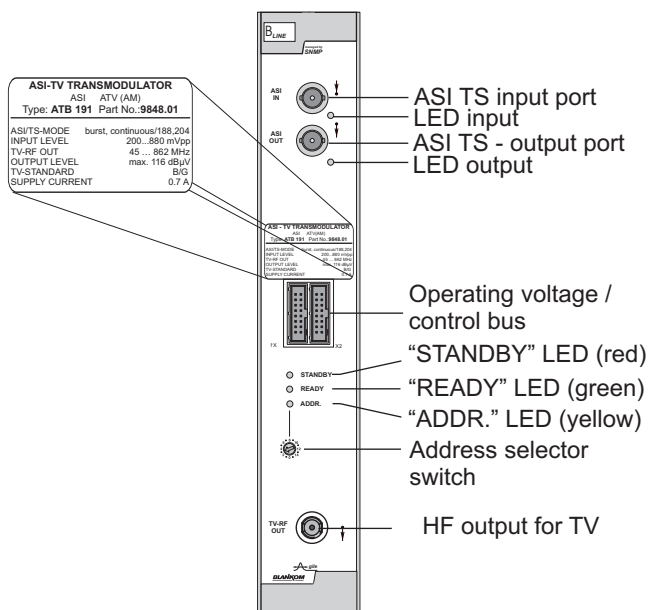

managed by
SNMP

3. Device variant

ATB 191 9848.01 ASI ATV(AM)

Minimum software requirements for HCB 100:

9650.03: Version 2.34*

9650.04/05: Version 3.18*

*) Updates: www.blankom.de

4. General

The ATB 191 ASI TV transmodulator is one component of the B-LINE headend system which has been designed as a complete package for medium-sized distribution networks. It is the component which selects a programme from the ASI transport stream and converts it into an analogue cable TV channel. All the components are programmed via a single central control unit and thereafter each component will function independently.

5. Function description

With this transmodulator, the digital ASI signal is decoded and then transferred into a serial data stream. Next, that data stream is parallelised and fed into a FIFO system. The timing of this data input will in all cases be calculated from how full the FIFO system is and adapted to the general data input rate. If 78 Mbit/s is exceeded, an alarm message will be sent. The regeneration system for the transport stream SPI protocol follows at the FIFO system output, and at the same time, recognition of the transport stream being correct is ensured. It is at this level that the transport stream can be edited.

From the transport stream, the succeeding MPEG decoder selects a programme and generates an analogue video signal and a digital audio signal. In the D/A converter which comes next; these two are converted into two analogue audio channels. The analogue signals are fed into separate modulators and then aggregated in the IF (intermediate frequency) position. Then the IF filtering takes place, and after that the production in the desired output channel. The fact that mixers are used which can accommodate a high output, also fractional N-PLLs, guarantees high-quality transmission. There is a free choice of frequency in the output channel from 45 to 862 MHz. On the output side, the modulator does not leak to adjacent channels. If the output level changes, the red LED will flash. Every time the level or frequency figures are programmed, automatic measurement of the reference level takes place; this function will, however, not start until 100 seconds have elapsed after start-up of the system. When the output load changes (perhaps because the output cable is disconnected), a warning and display item for a level fault may also appear. When the fault has been identified, the appropriate SNMP TRAP message will be sent. Use of this function is optional.

6. Adjustments

6.1 Adjustment with the Headend Controller

- Adjustment of the addresses at the Bus Extender BEB 100 and at the modules
- Activation of the programming mode of each module by selecting the line (BEB 100) and the module position (01... 15) at the Headend Controller (HCB 100)
 - yellow LED will be lit up til the beginning of the parameter adjustment
- Adjustment of the ATB 191 parameter (see chapter 9)
 - green LED is lit up
- After the programming the ATB 191 will be automatically switched into the operating status
 - yellow LED lights up briefly / green LED is lit up

6.2 Adjustment with the PC / Laptop

- Condition for the remote programming is an "online - connection" after IP - standard and an ethernet connection at the PC / Laptop
- Adjustment of the line / position addresses at the Bus Extender BEB 100 as well as at the modules
- At the Headend Controller HCB 100 IP - address input (e.g. 192.168.001.001)
- For "direct connection" between a PC and HCB 100 use a crossed patch cable (RJ 45)
- For connection over a deviation use an uncrossed patch cable
- HTML - browser start-up and put in IP - address as target address
- If connected correctly the HTML - control surface at the PC will open up and a blue LED (LINK) at the HCB 100 will be lit up
- All adjustment of the modules are specified at the control surface

The manual instructions of the Headend Controller HCB 100 and the Bus Extender BEB 100 have to be considered!

7. Meaning of LED signals**7.1 LED`s for the ASI ports**

Colour	Status	Meaning of display
Green	Permanently illuminated	ASI channel has been configured as input
	Flashing	No ASI signal
Yellow	Permanently illuminated	ASI channel has been configured as output
	Flashing	No ASI signal

7.2 LED`s on front panel

Colour	Status	Meaning of display
Red	Permanently illuminated	Component is on standby
	Flashing	Component faulty (hardware) or level fault
Green	Permanently illuminated	Component working, everything ok
	Flashing	Error warnings, depending on signal: ASI without sync (e.g. when there is no input signal) Service setting not valid
Yellow	illuminated or flashing	Remote control making contact / data being exchanged

8. Programming from the Web server*

8.1 Main menu

ASI-TV TRANSMODULATOR, ATB 191 (9848.01 / 00), Address 00 / 04	
Description	MDR Thüringen
Input	
Status	SYNC
Program settings	
Program listing	<input type="button" value="Load"/>
Service ID	28230 dez
Language	0
Language code	ger
Service type	TV
Output	
Frequency table TV standard B/G	E12 (224.250 MHz)
Attenuation	31,5 dB
Module settings	
Operating status	On [On]
Transmit trap	On
SYNC check	fast
Level monitoring	On
<input type="button" value="Software Option"/> <input type="button" value="Extended settings"/> <input type="button" value="Status"/>	
<input type="button" value="Default set"/> <input type="button" value="Update"/> <input type="button" value="Clear"/> <input type="button" value="Transmit"/>	
<input type="button" value="<<<"/> <input type="button" value="Back"/> <input type="button" value=">>>"/>	

Name of device, item number, address in headend

Name Name of programme (max. 30 characters)

Input Status Shows whether there is **SYN**Chronisation or **noSYN**Chronisation at input port

Programme settings

List of programmes See Menu 2
Service ID Service number, choose a no. 0 to 65535
Language Language number, choose a no. 0 to 255
Language code Shows the code for the language selected
Type of service Shows the type of service selected (TV, radio)

Output

Table of channels Channels to choose from
B/G standard (Channel, a no. 2 to 69, B/G standard)
Attenuation Can be set between 0 and 31.5 dB

Components settings

Operating status The options are: On, Off, Reset
Send TRAP For TRAP messages. Choice: On or Off
SYNC check Checks SYNC at input port. Choice: fast, normal, slow
Level control At output port. Choice: On or Off

Redirection to the relevant setting menus

Software option See Menu 1
Extended settings See Menu 3
Status See Menu 6
Factory settings See Menu 5

8.2 Software option (Menu 1)

ASI-TV TRANSMODULATOR, ATB 191 (9848.01 / 00), Address 00 / 04	
Activation software option	
Option	Status
Test line	activate
Subtitling	not activate
Enter licence key: <input type="text"/>	
Lizenz Index: 0 Device number: 0222128	
<input type="button" value="Back"/> <input type="button" value="Transmit"/>	

Name of device, item number, address in headend

Dialogue for entering code to activate the "test line" (CKB 101) and "subtitling" (CKB 102) software options. When the page is called up, the current state of activation for the relevant option will be displayed.

* Further details on this are to be found in the HCB manual

8.3 Loading the programme list (Menu 2)

ASI-TV TRANSMODULATOR, ATB 191 (9848.01 / 00), Address 00 / 04						
Program listing						
Program name	Status	Service type	Service-ID	Audio Language	Subtitle language	Selection
rbb Brandenburg	free	TV	28205	0;ger	missing	<input type="button" value="Set"/>
rbb Berlin	free	TV	28206	0;ger	missing	<input type="button" value="Set"/>
ARD-Online-Kanal	free	TV	28218	0;— ▾	missing	<input type="button" value="Set"/>
ARD-TEST-1	free	TV	28221	0;---	missing	<input type="button" value="Set"/>
ARD-TEST-2	free	TV	28222	0;ger	missing	<input type="button" value="Set"/>
NDR FS MV	free	TV	28224	0;ger ▾	missing	<input type="button" value="Set"/>
NDR FS HH	free	TV	28225	0;ger ▾	missing	<input type="button" value="Set"/>
NDR FS NDS	free	TV	28226	0;ger ▾	missing	<input type="button" value="Set"/>
NDR FS SH	free	TV	28227	0;ger ▾	missing	<input type="button" value="Set"/>
MDR Sachsen	free	TV	28228	0;ger ▾	missing	<input type="button" value="Set"/>
MDR S-Anhalt	free	TV	28229	0;ger ▾	missing	<input type="button" value="Set"/>
MDR Thüringen	free	TV	28230	0;ger ▾	missing	<input type="button" value="Set"/>
SWR Fernsehen RP	free	TV	28231	0;ger	missing	<input type="button" value="Set"/>
						<input type="button" value="Update"/> <input type="button" value="Back"/>

This menu contains a list of all services contained in the data stream. Language selection can take place here if available. Any service is adopted or given new settings by clicking the relevant "Set" button.

8.4 Extended settings (Menu 3)

ASI-TV TRANSMODULATOR, ATB 191 (9848.01 / 00), Address 00 / 04	
Video	
Video output	On
Colour bar	Off
Colour system	PAL
Video format	letterbox
Audio settings	
Audio gain	0 dB
Audio mode	auto
Output	
Sound deviation	30 kHz
Sound carrier2	On
Picture carrier frequency	224250 kHz
VPS settings	
CNI code	0x000
Source audiomode	MPEG
Source PIL	A056 (PDC)
Complementary data	
Teletext	On
WSS insertion	On
Subtitling	
Mode	Off
Settings DVB subtitling	
DVB language index	0
DVB language code	---
Use extended ID's	yes
Composition Page ID	0 dez
Ancillary Page ID	0 dez
Settings Teletext subtitling	
Teletext site	0
Background	opaque
Character mode	auto
The following settings are used only in the manual character mode!	
Basic character	Latin
Supplementary character	Latin
National table	standard table
Test lines	
Line 17	Off
Line 18	Off
Line 330	Off
Line 331	Off
Extended monitoring options	
Internal AVsync info	On
Manual settings	
Update Clear Transmit	
Back	

Name of device, item number, address in headend

Video

Video output
Colour palette bar
Colour standard
Video format

For setting the video parameters
The options are: On, auto off, auto colour palette bar
The options are: On or Off
The options are: PAL, SECAM, NTSC
The options are: Letterbox, center cut, 1:1, pillarbox, 4:3 vertical cut, 20:9 letterbox

Audio settings

Audio amplification
Audio mode

Can be set between +6 and 20 dB
The options are: auto, monoL, monoR, stereo, dual, dual inverse (for 2 carriers)
Auto, monoL, monoR, monoL+R (for 1 carrier)

Output

Sound deviation

The options are: 30 kHz (for 2 carriers)
30 kHz, 50 kHz (for 1 carrier)

Sound carrier 2

Image carrier frequency

The options are: On or Off
Frequency to be entered in kHz, automatic rounding up or down to next 10 kHz on adoption

VPS settings

CNI code

Can be freely selected, hexadecimally (0x000 to 0xFFFF)

Source audio mode

Source PIL

The options are: MPEG, A056(MPEG)
The options are: A056(PDC), A056, PDC, Timer Control Code

Additional data

Teletext
WSS feed

The options are: On or Off
The options are: On or Off

Subtitling

(will only be available if "Subtitling" option is on)

Mode

Selection: OFF, Teletext, DVB

Adjustments DVB-Subtitling

(will only be available if "Subtitling" option is on)

DVB languages index
language code
Any extended IDs used
Composition page ID
Ancillary page ID

Free choice between 0 and 255 DVB
Shows the code for the language selected
The options are yes or no
Shows the ID (decimal figure)
Shows the ID (decimal figure)

Settings for teletext subtitling

(will only be available if "Subtitling" option is on)

Teletext page
Background

Free choice between 0 and 65535
The options are: not transparent, semi-transparent, transparent, black transparent

Font mode

The options are: auto or manual

The following parameters only apply if the manual mode has been selected for the font:

Standard font

The options are: Latin, Cyrillic-1, Cyrillic-2, Cyrillic-3, Arabic, Greek, Hebrew

Additional font

The options are: Latin, Cyrillic, Arabic, Greek

Table of countries

The options are: standard table, alternative table
no country code, English, German, Swedish, Italian, French, Spanish, Czech, Rumanian, Polish, Estonian, Latvian, Serbian, Turkish, Danish

Test lines

(will only be available if "Test lines" option is on)

Line 17
Line 18
Line 330
Line 331

A test signal can be sent on all four of these lines, and the signal choice is: off, CCIR 17, CCIR 18, CCIR 330m, CCIR 331, sine (x)/x, ramp

Extended display options

Internal AVsync info

Display option on status page (Menu 6): the options are On or Off

Redirection to the relevant settings menu

Manual settings

See Menu 4

8.5 Manual settings (Menu 4)

ASI-TV TRANSMODULATOR, ATB 191 (9848.01 / 00), Address 00 / 04		
PCR for current service		
Use PCR-PID	<input type="text" value="0"/>	dez
Manual PID settings		
PCR-PID	<input type="text" value="0"/>	dez
Video-PID	<input type="text" value="0"/>	dez
Audio-PID	<input type="text" value="0"/>	dez
Teletext-PID	<input type="text" value="0"/>	dez
VBI-PID	<input type="text" value="0"/>	dez
Subtitle-PID	<input type="text" value="0"/>	dez
Composition Page-ID	<input type="text" value="0"/>	dez
Ancillary Page-ID	<input type="text" value="0"/>	dez
<input type="button" value="Update"/> <input type="button" value="Clear"/> <input type="button" value="Transmit"/>		<input type="button" value="Back"/>

Name of device, item number, address in headend

PCR for current service

Use PCR-PID Free choice
between 0 and 65535

Manual PID settings

PCR-PID Free choice: a no. 0 to 65535
 Video PID Free choice: a no. 0 to 65535
 Audio PID Free choice: a no. 0 to 65535
 Teletext PID Free choice: a no. 0 to 65535
 VBI PID Free choice: a no. 0 to 65535
 Subtitle PID Free choice: a no. 0 to 65535
 Composition Page ID Free choice: a no. 0 to 65535
 Ancillary Page ID Free choice: a no. 0 to 65535

8.6 Factory settings (Menu 5)

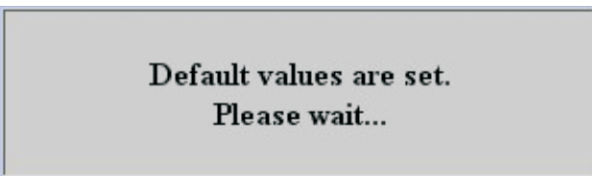

When this menu is called up, all the settings made on the EEPROM will be deleted and replaced by the default settings. The modul will go back to these default values. Once the setting process is over, there will be automatic return to the main menu.

8.7 Status of device (Menu 6)

ASI-TV TRANSMODULATOR, ATB 191 (9848.01 / 00), Address 00 / 04		
ASI input		
Status	SYNC	
Information	TS packet size: 188 Byte MPEG data rate: 38.15104 Mbps	
MPEG Decoder		
Status	TS: SYNC Audio Decoder: SYNC Video Decoder: SYNC	
SysClock	PcrPID,iSync,DPLL/set, ok, 7ppm	
AudioSync	AvgDiff,SR,updSync,fill/-24, 1, ok, 3056	
Videosync	Diff,SR,nUpdSync/1759, 1, 804	
Complementary data		
Current VPS data	PLL= 07.10 07:45 Running Audio= stereo CNI= 0x0DFE	
Current WSS data	4:3 full A056_WSS 0x8 4:3	
Test line insertion	Line 17: Off Line 18: Off Line 330: Off Line 331: Off	
Status output		
Signal level	ok	
Status PLL 1 / 2	ok / ok	
Sound carrier 1 / 2	5,5 / 5,74 MHz	
Software versions		
AP Controller	9848.01-81.01 AP-Controller V1.00 06.10.2008 JH	
MPEG	9611.01-86.01 (Dual) MPEG_CI V1.17 08.09.08 SS	
Internal controller	9199.01-88.01 internal Controller V1.03 06.04.2008 JH	
FPGA MC	9850.02-88.01 FPGA Download Controller V1.35 08.09.2008 MF,PK	
FPGA	9848.01-87.01 ASI Input FPGA V1.02 07.08.2008 WE,MF	
Information		
Temperature AP	29 °C	
Device number	0222128	
Device index	00	
<input type="button" value="Update"/> <input type="button" value="Back"/>		

Name of device, item number, address in headend

ASI input

Status Synchronisation status
Information Details of TS packet length and MPEG data rate

MPEG decoder

Status Synchronisation status for the TS and the audio and video decoder

The following will only be displayed if the internal AVsync info option is switched on (see Menu 3)

SysClock Details of system timing

AudioSync Extended details of synchronisation status of the audio decoder

VideoSync Extended details of synchronisation status of the video decoder

Additional data

Current VPS data Shows detailed information about current VPS data

Current WSS data Shows detailed information about current WSS data

The following will only be displayed if the "test lines" option is switched on:

Test line entry Shows which test signal is set for the 4 lines

Output status

Signal level Shows status of signal level at output (ok, too high, too low)

Status PLL1/2 Shows whether or not PLL1 (or PLL2) is activated (ok, not ok)

Sound carrier 1/2 Shows frequency of sound carrier 1 or 2

Software versions

Shows the software versions for the controllers as follows:

- Controller of terminals board
- MPEG controller
- Controller of IF converter
- Download controller for FPGA ASI input
- FPGA ASI input

Information

AP temperature Temperature of terminals board

Device number Shows the device number

Device index Shows the device index

9. Manual menu control at the headend controller (HCB 100)

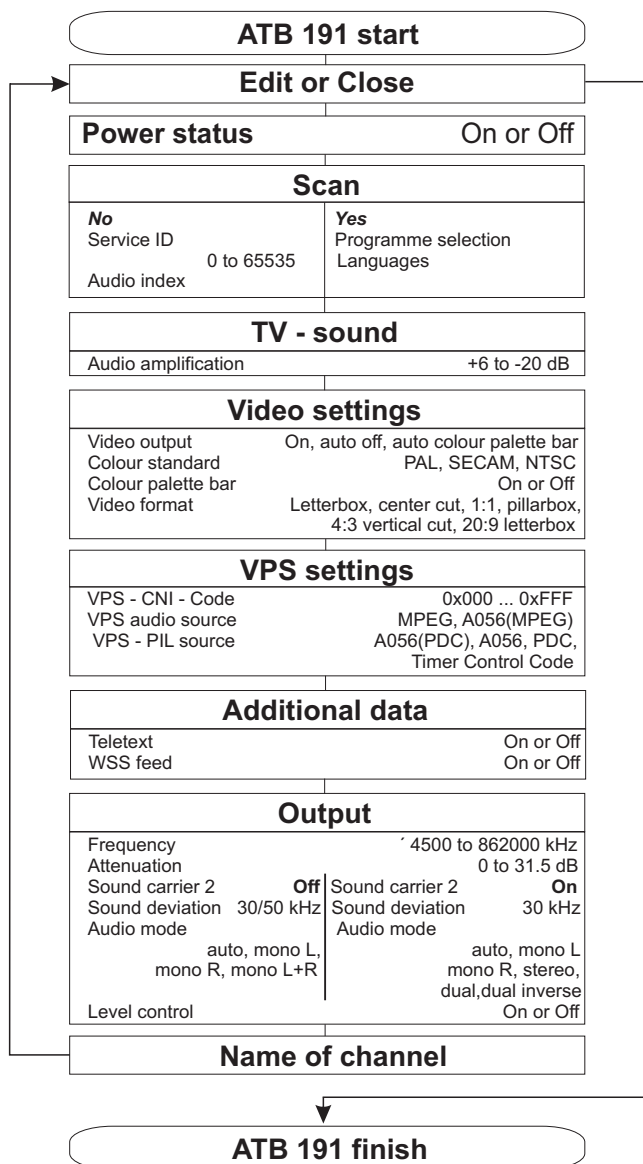

10. TRAP messages

Serial no.	Message	Message type	Notes
01	Signal OK	INFORMATION	Component working, everything ok
02	Input not sync	WARNING	Input not synchronised
03	MPEG Error	CRITICAL	MPEG error
04	System reset	WARNING	System has been reset after internal error
05	MPEG-Decoder not sync	WARNING	MPEG decoder not synchronised
06	Power fail	CRITICAL	Error in power supply
08	IIC Error	CRITICAL	Error in IIC or internal hardware
09	Output Signallevel too small	WARNING	Level of output signal too low
10	Output Signallevel too large	WARNING	Level of output signal too high
11	Output Signallevel ok	INFORMATION	Level of output signal ok
12	PLL error	CRITICAL	PLL at output not activated
13	Tonmode Mono L+R	INFORMATION	Sound mode set as mono total
14	Tonmode Mono L	INFORMATION	Sound mode set as mono on left
15	Tonmode Mono R	INFORMATION	Sound mode set as mono on right
16	Tonmode Stereo	INFORMATION	Sound mode set as stereo
17	Tonmode Dual	INFORMATION	Sound mode set as dual
18	Tonmode Dual invers	INFORMATION	Sound mode set as dual inverse

11. Block diagram

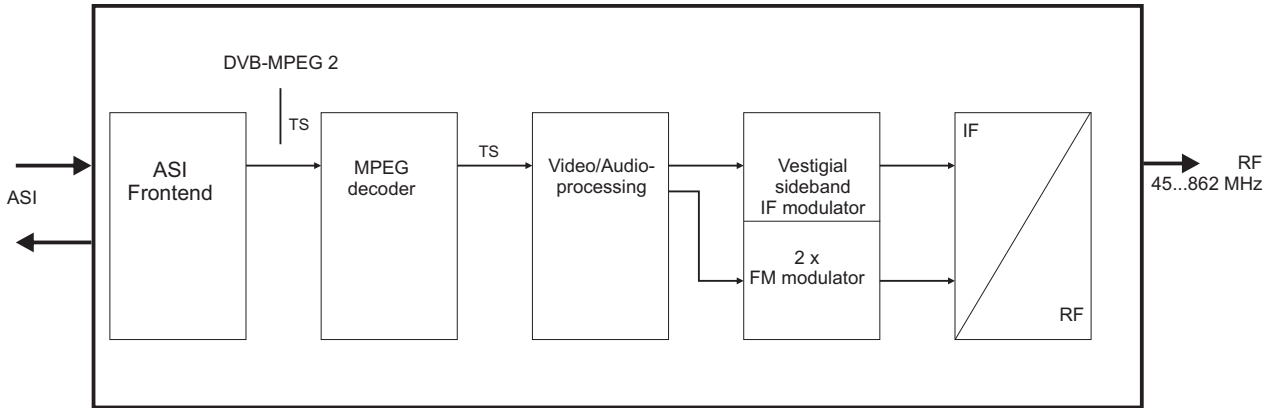

12. Headend BUS structure

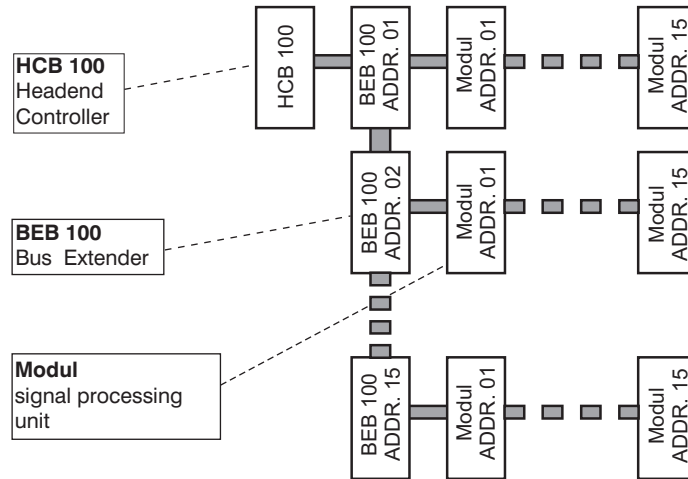

The number of the possible module connections (00 ... 15) to a BEB 100 depends on the total power consumption of this line!

13. Example of use

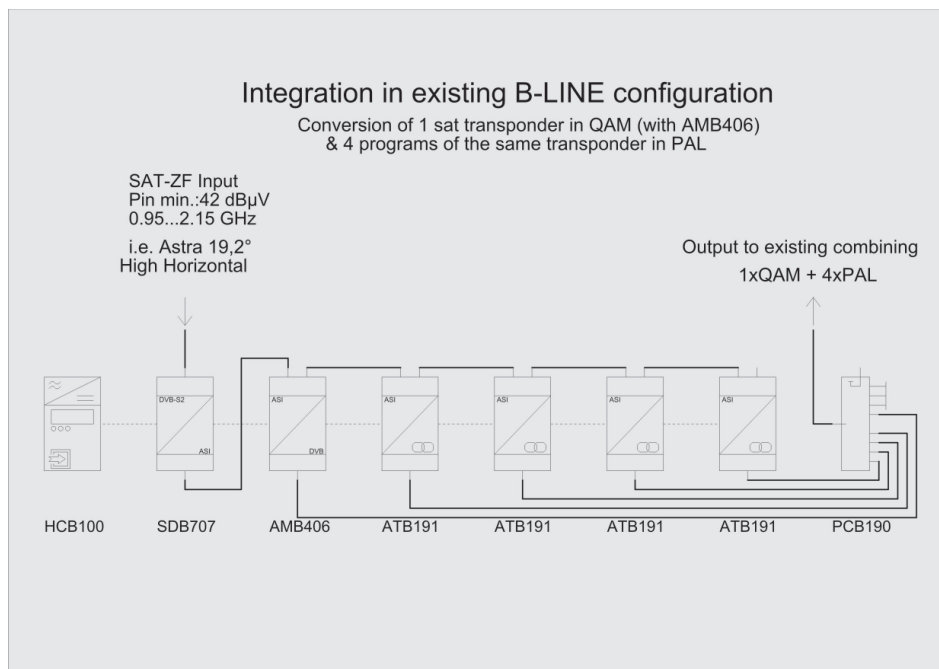

14. Technical data

ASI input

Level range	200 to 880 mV _{pp}
Data rate	270 Mbps
Connector type	BNC socket
Impedance	75
ASI polarity	regular/inverted

ASI output

Level	800 mV _{pp} (± 10 %)
Data rate	270 Mbps
Connector type	BNC socket
Impedance	75
ASI polarity	Normal

ASI signal processing

Data rate	0.625 to 78 Mbps
ASI transfer format	
Input	Continuous, burst
Output	Burst
TS transfer format	
Input	188, 204 Byte
Output	188, 204 Byte
Signal processing	EN 50083-9 [1]

TV output

TV standard	B/G
Sound type	Double carrier FM
Sound carrier frequencies	5.5 / 5.742 MHz above the picture carrier
Sound mode	Mono / stereo / dual / auto (VPS-controlled)
Audio deviation 1 mono-carrier	30 / 50 kHz
Audio deviation 2 mono-carrier	30 kHz
Audio deviation dual sound	30 kHz
Output frequency range	45 to 862 MHz
Steps for tuning	10 kHz
Output level	Max. 116 dBµV
Range for level adjustment	0 to 31.5 dB (in 0.5 dB steps)

Channel allocation	Adj.channel compatible
Connector type	F socket
Impedance	75
Return loss	18 dB 45 MHz -1.5 dB/Octave

Signal quality

Mono channel intermodulation	66 dB
Signal to noise ratio (S/N) 3rd order	60 dB
Spurious emission 45 to 862 MHz	60 dB
C/N in the channel (BW = 4.8 MHz)	Typically 69 dB
C/N (> 25 MHz, distance from centre of channel; BW = 4.8 MHz)	Typically 80 dB
S/N ratio parallel sound	
not measured / measured	Typically 62/ 56 dB
Output level stability	max. 1 dB _{pp}
Frequency stability	± 30 kHz

Operating parameters

Current / voltage	12 V (± 0.2 V) / 700 mA
Residual ripple of supply voltage	10 mV _{pp}

Environmental conditions

Temperature range	-10 ... +55 °C
Temperature range (for data keeping)	5 ... 45 °C
Relative humidity	80 % (non condensing)
Method of mounting	vertical
Location of mounting	splash-proof and drip-proof

Physical information

Dimensions (l x w x h)	
without 19" - adapter	50 x 276 x 148 mm
with 19" - adapter	50 x 301 x 148 mm
Weight	1,300 g

Delivery content

1 x BUS connection

Software option

Test lines	CKB 101 9650.51
Subtitling	CKB 102 9650.52

15. Glossary

AM	A mplitude m odulation
AP	A nschluss p latte (Terminals board)
ASI	A synchronus S erial I nterface
ATV	A nalogue T elevision
AV	A udio/ V ideo
BW	B and w idth
CCIR	C omité C onsultatif I nternational R adiocommunication
C/N	C arrier to N oise ratio
D/A	D igital/ A nalogue
DVB	D igital V ideo B roadcasting (DVB-C Cable, DVB-S Satellite, DVB-S2 Satellite 2)
ETSI	E uropean T elecommunications S tandards I nstitute
FIFO	F irst I n – F irst O ut
FPGA	F ield P rogrammable G ate A rray
HF	H igh f requency
http	h ypertext t ransfer p rotocol
ID	I dentifier
IF	I ntermediate F requency
IIC	I nter- I ntegrated C ircuit (data bus within device)
IP	I nternet P rotocol
KST	K opf s telle (headend)
LED	L ight E mitting D iode
MC	M icro C ontroller
MIB	M anagement I nformation B ase
MPEG	M oving P icture E xperts G roup
NIM	N etwork I nterface M odule
PCR	P rogram C lock R eference
PDC	P rogram D elivery C ontrol
PID	P rogram I dentifier
PLL	P hase L ocked L oop
PMT	P rogram M ap T able
RF	R adio F requency
SNMP	S ingle N etwork M anagement P rotocol
SPI	S erial P eripheral I nterface
SPTS	S ingle P rogram T ransport S tream
TS	T ransport S tream
TV	T elevision
VPS	V ideo P rogramming S ystem
WSS	W ide S creen S ignal

16. Bibliography

[1] EN 50083-9: Cabled distribution systems for television, sound and interactive multimedia signals, part 9: Interfaces for CATV/SMATV headends and similar professional equipment for DVB/MPEG-2 transport streams

[2] EN 50083-1: Cabled distribution systems for television, sound and interactive multimedia signals, safety requirements

17. History

Version	Date	Modification	Editor
1.00	28.10.2008	Basic document	Häußer, Poch

Options and other TV standards available upon request! Changes due to technical progress possible!