

Operating instructions

COFDM Modulator

ASI-TS → DVB-T (COFDM)

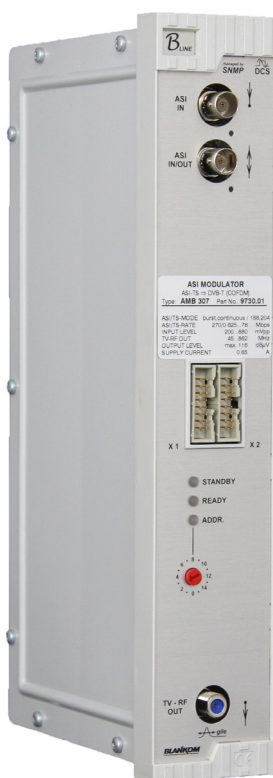

Contents

1. Safety and operating instructions	2
2. Device variants	2
3. General	2
4. Front view	3
5. Function description.....	3
6. Adjustments	3
6.1 Adjustment with the Headend Controller	3
6.2 Adjustment with PC / laptop	3
7. Meaning of LED signals	4
7.1 LED`s for the ASI ports	4
7.2 Status LED`s on front panel.....	4
8. Programming by web server	5
8.1 Main menu	5
8.2 Extended settings	6
8.3 NIT entries	6
8.4 Program filter	6
8.5 Data rate overview	6
8.6 Table processing	7
8.7 Configuration channel list	7
8.8 Software overview	8
8.9 Device status	9
8.10 Factory settings	9
9. Manual menu control with Headend Controller	10
10. SNMP Trap messages	10
11. Block diagram	11
12. Head end bus structure	11
13. Application example	12
14. Technical data	12
15. Glossary	13
16. Bibliography	13
17. Document history	13



AMB 307
Part N°: 9730.01

1. Safety and operating instructions



When assembling, starting-up and adjusting the modules, it is necessary to consider the system specific references in the manual instruction!



The modules may only be installed and started up by authorized technical personnel!



When assembling the modules into the receiving points, the adherence of the EMC regulations is to be secured!



The assembly and wiring have to be done without voltage!



All active modules may only be operated with the Headend Controller HCB x00 or Bus Extender BEB x00!



The main voltage and the operating voltage of the modules working by DC have to be in compliance to the operating parameters described in the technical data.



With all work the defaults of the DIN EN 50083 have to be considered! Especially the safety relevant execution of the DIN EN 60728-11 [2] is necessary!

2. Device variants

AMB 307 9730.01 ASI-TS → DVB-T (COFDM)

Minimum software requirements for HCB x00:

9650.03: Version 2.34*

9650.04/.05: Version 3.18*

9652.01: Version 3.23*

*) Updates: www.blankom.de

3. General

The COFDM modulator AMB 307 is a module of the head end system B-LINE which is conceived as a complete system for middle-sized networks. The module converts one (or two, if hierarchical modulation selected) ASI stream(s) into the digital standard DVB-T. The signal will be transcoded from the ASI transport stream into cable TV channels. All modules will be programmed via a central control unit (HCB x00) and are working fully independent afterwards. The status of the modules are displayed via LED's (see chapter 7.2 „Status LEDs on front panel“).

4. Front view

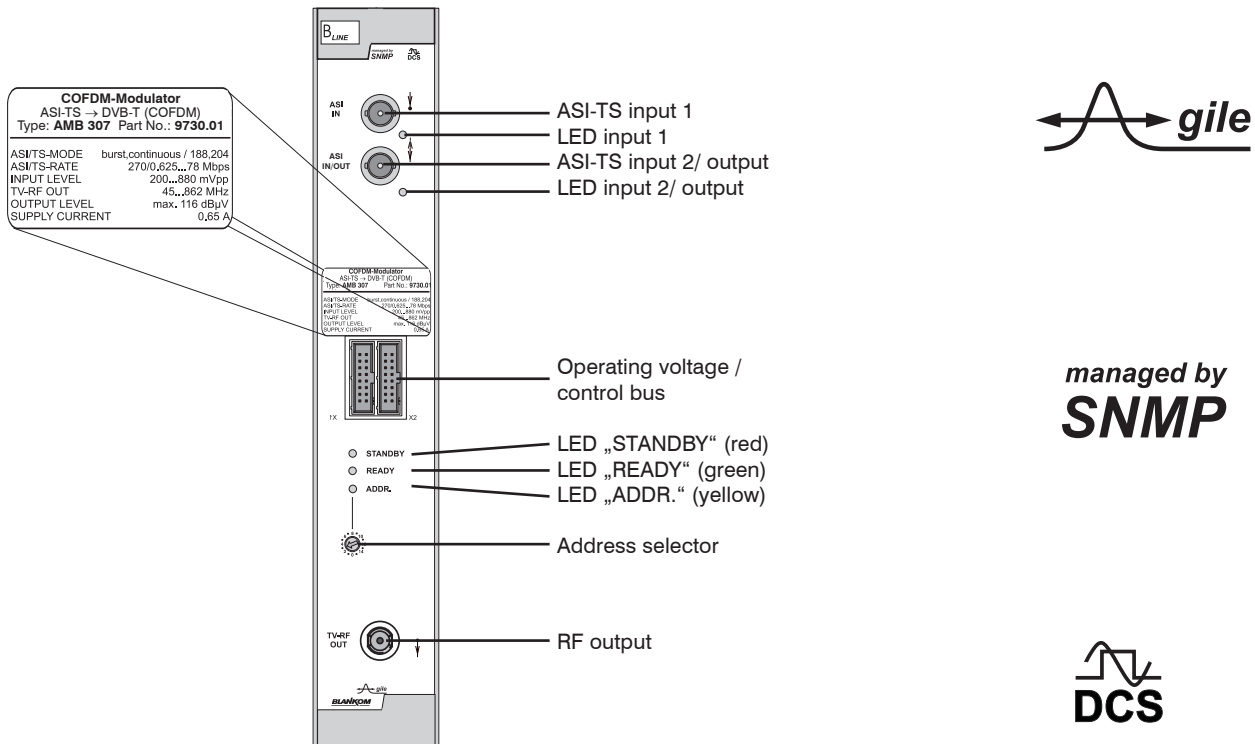

5. Function description

The data stream which results from the ASI input is passed to a FIFO. All services of the resulting transport stream which shall be processed into the COFDM modulator will be chosen by controlling software of the module. The SI and PSI tables affected (i.e. the PAT, PMT, SDT, EIT) are automatically corrected. From the Headend Controller informations are provided to generate a complete NIT (Network Information Table) into the transport stream. This is required to enable the receiver (such as Set-Top-Box) to tune in automatically. The changed SI and PSI tables are fed into the COFDM modulator and an IF signal is generated at the output channel. There is a free choice of frequency in the output channel from 45 to 862 MHz. On the output side, the modulator does not leak to adjacent channels. So that errors in level can be signalled if the load fluctuates (the red LED will flash and a trap message will be sent), a reference level is generated. Every time the level for frequency figures are programmed, automatic measurement of the reference level takes place; this function will, however, not start until 100 seconds have elapsed after start-up of the system. This function can be enabled or disabled in the main menu.

6. Adjustments

6.1 Adjustment with the Headend Controller

- Adjustment of the addresses at the Bus Extender BEB x00 and at the modules
- Activation of the programming mode on each module by selecting the line (BEB x00) and the module position (01... 15) at the Headend Controller(HCB x00)
 - yellow LED illuminates until the beginning of the parameter adjustment
- Adjustment of the AMB 307 parameters (see chapter 9) → green LED is switched on
- After the programming the AMB 307 will be automatically switched into the operating mode
 - yellow LED flashes shortly / green LED is switched on

6.2 Adjustment with PC/ laptop

- Prerequisite for the remote programming is an "online - connection" according to the IP standard and an ethernet connection at the PC/ laptop
- Adjustment of the line/ position addresses at the Bus Extender BEB x00 as well as at the modules
- At the Headend Controller HCB x00 input IP address (e.g. 192.168.001.001)
- For "direct connection" between a PC and HCB x00 use crossover cable (RJ 45)
- For connection over a HUB use a normal straight through patch cable
- Start-up HTML browser and put in IP address as target address
- If connected correctly the web interface will be opened on the PC/ laptop and a blue LED (LINK) at the HCB x00 will be lit up.
- All adjustments of the modules are specified on the web interface.

The manual instructions of the Headend Controller HCB x00 and the Bus Extender BEB x00 have to be considered!

7. Meaning of LED signals

7.1 LED`s for the ASI ports

Colour	Status	Meaning of display
green	permanently illuminated	ASI channel has been configured as input
	flashing	no ASI signal
yellow	permanently illuminated	ASI channel has been configured as output
	flashing	no ASI signal

7.2 Status LED`s on front panel

Designation (Colour)	Status	Meaning of display
STANDBY (red)	permanently illuminated	Module is on standby
	flashing	Module faulty (hardware) or level error
READY (green)	permanently illuminated	Module working, everything ok
	flashing	Dysfunction depending in signal: ASI not sync (e.g. in case of missing input signal) no input on the COFDM modulator buffer overflow in the COFDM modulator
	off	RF output is deactivated
ADDR. (yellow)	illuminated or flashing	Remote control making contact/ data transmission

8. Programming by web server *

8.1 Main menu

COFDM MODULATOR, AMB 307 (9730.01 / 00), Address 00 / 00			
Description	xxxx		
Transport stream	High priority	Low priority	
Input			
TS-Input	ASI 1	ASI 2	
Status	SYNC	no SYNC	
Data rate	38.015	0.000	Mbps
Output			
Channel (Norm: B/G)	S21 (306.00 MHz)		
Attenuation	5		dB
RF-Signal	On		
Transmission mode	2K		
Constellation	64QAM		
Bandwidth	8MHz		
Guard interval	1/4		
Code rate	2/3	2/3	
Status			
Operating mode COFDM-Modulator	Transcoder		
Hierarchical modulation	On(Alpha=1)		
NIT-Processing	Off	Off	
CAT-Processing	Off	Off	
Change TS-Identification	Off	Off	
Program filter	On / Change	Off / Change	
Data rate overview	Load	Load	
Operating status	On	[On]	
SNMP-Trap message	On		
Level monitoring	On		
Factory settings	Load		
<input type="button" value="Extended settings"/> <input type="button" value="NIT table"/> <input type="button" value="Software overview"/>			
<input type="button" value="Table processing"/> <input type="button" value="Status"/>			
<input type="button" value="Reload"/> <input type="button" value="Transmit"/>			
<input type="button" value="Back"/>			

Name of device, item number, module address in head end

Description module name (max. 30 characters)

Transport stream displays the priority of both TS, if hierarchical modulation was selected (menu 1)

Input
TS-Input displays ASI input respective selection of the input of the second TS, if hierarch. modulation was selected.

Status display whether **SYNC**hronization or **noSYNC**hronisation with input

Data rate displays the data rate of the TS

Output
Channel channel selection : 2 ... 69, standard B/G, 2 ...134, standard M

Attenuation adjustment range 0 ... 31.5 dB

RF signal: selection: On/ Off

Transmission mode selection: 2k/ 8k

Constellation selection: 16 QAM, 64 QAM, QPSK

Bandwidth: selection: 5, 6, 7, 8 MHz

Guard interval: selection: 1/32, 1/16, 1/8, 1/4

Code rate: selection: 1/2, 2/3, 3/4, 5/6, 7/8

Status

Operating mode COFDM-Modulator according adjustment menu 1

Hierarchical modulation according adjustment menu 1

NIT-Processing On/ Off according adjustment menu 5

CAT-Processing On/ Off according adjustment menu 5

Change TS-Identificat. On/ Off according adjustment menu 5

Program filter On/ Off according adjustment menu 3

Data rate overview see menu 4

Operating mode selection: On/ Off/ Reset

SNMP-Trap message selection: On/ Off, if SNMP option in HCBx00 enabled, otherwise „locked“ display

Level monitoring selection: On/ Off

Factory settings setting the default values (see menu 9)

Routing to the appropriate adjustment menu

Extended settings see menu 1

NIT table see menu 2

Program filter see menu 3

Table processing see menu 5

Software overview see menu 7

Status see menu 8

* Further details on this are to be found in the HCB manual

8.2 Extended settings (menu 1)

COFDM MODULATOR, AMB 307
(9730.01 / 00), Adresse 00 / 00

Ausgang

Norm (Kanaltabelle) B/G ▾

Frequenz 306000 kHz

Betriebsart COFDM-Modulator Transcoder ▾

Hierarchische Modulation Ein (Alpha=1) ▾

Spektrum normal ▾

Aktualisieren Zurück Senden

Name of device, item number, module address in head end

Output

Standard (channel table)
Frequency
Operating mode
COFDM-Modulator
Hierarchical modulation
Spectrum

selection: B/G, M
adjustment range 45000 ... 862000 kHz
selection: Transcoder, Test level, Test signal
selection: Off, On (Alpha=1), On (Alpha=2), On (Alpha=4)
selection: normal/ invers

8.3 NIT entries (menu 2)

COFDM MODULATOR, AMB 307
(9730.01 / 00), Adresse 00 / 00

Entry	Original TS ID	Original Network ID	Frequency (MHz)	Bandwidth	Constellation	Hierarchical modulation	HP Code rate	LP Code rate	Guard interval	Transmission mode
1	1	4369	306000	8MHz	64QAM	On (Alpha=1)	2/3	2/3	1/4	2k
2	43243	67	330000	7MHz	16QAM	Off	3/4	1/2	1/16	8k
3	434	3	338000	8MHz	64QAM	Off	7/8	1/2	1/8	2k
4	1	133	346000	8MHz	64QAM	On (Alpha=2)	2/3	5/6	1/8	8k
5	7	133	354000	8MHz	QPSK	Off	5/6	1/2	1/8	2k

NIT distribution: statically
Network name: none
Network ID: 0

Clear entries Reload Back

Name of device, item number, module address in head end

NIT entries with all information available

8.4 Program filter (menu 3)

COFDM MODULATOR, AMB 307
(9730.01 / 00), Adresse 00 / 00

Program filter configuration

Filter function On ▾

Other transponder information Pass ▾

Program selection

Operating mode Pass ▾

Service ID	Program name	Selection
0x0001	MEGASPORT	<input checked="" type="checkbox"/>
0x0002	OTV	<input type="checkbox"/>
0x0003	1PLUS1	<input type="checkbox"/>
0x0004	TV KYIV	<input type="checkbox"/>
0x0005	K1	<input type="checkbox"/>
0x0006	K2	<input type="checkbox"/>
0x0007	1PLUS1 Intern-1	<input type="checkbox"/>
0x0008	1PLUS1 CINEMA	<input type="checkbox"/>

Reverse selection Select all Clear all
Data rate overview

Reload Back Transmit

Name of device, item number, module address in head end

Program filter configuration

Filter function
Other transponder information

selection: On/ Off

Other transponder information

pass or drop of additional informations (e.g. electronic program guide), wich are contained in data stream as "other"

Program selection

Operating mode

pass or drop of the marked programs

Reserve selection

all not marked programs are choosen or vice versa

Select all

all programs of the list are marked

Clear all

no program of the list is marked

Data rate overview

routing to menu 4

8.5 Data rate overview (menu 4)

COFDM MODULATOR, AMB 307
(9730.01 / 00), Adresse 00 / 00

Input data rate	38.014 Mbps
Data rate by filter	5.134 Mbps
Available netto data rate	10.555 Mbps
Reserve	5.420 Mbps

Reload Back

Name of device, item number, module address in head end

Input data rate
Data rate by filter
Available netto data rate
Reserve

net data rate at the input
net data rate by program filters
max. possible net data rate
max. netto data rate minus data rate by filter

8.6 Table processing (menu 5)

COFDM MODULATOR, AMB 307 (9730.01 / 00), Address 00 / 00			
Transport stream	High priority	Low priority	
NIT			
NIT-Processing	Off ▾	Off ▾	
Network name	none	none	
Network ID	0	0	dez
Channel number insertion	Off ▾	Off ▾	
Channel list	Configure	Configure	
CAT			
CAT-Processing	Off ▾	Off ▾	
CA-System ID	0	0	dez
Operator ID	0	0	dez
Transport stream			
Change TS-Identification	Off ▾	Off ▾	
Transport stream ID	0	0	dez
Network ID	0	0	dez
Reload Back Transmit			

Name of device, item number, module address in head end

Transport stream displays the priority of both TS, if hierarchical modulation was selected (menu 1)

NIT

NIT-Processing selection: On/ Off
Network name adjustment range: max. 30 characters
Network ID adjustment range: 0...65535

Channel number insertion

selection: On/ Off

Channel list

see menu 6

CAT

CAT-Processing selection: On, On (CA Filter), Off
CA-System ID adjustment range: 0...65535
Operator ID adjustment range: 0...65535

Transport stream

Change TS-Identific. selection: On/ Off
Transport stream ID adjustment range: 0...65535
Network ID adjustment range: 0...65535

8.7 Configuration channel list (menu 6)

COFDM MODULATOR, AMB 307 (9730.01 / 00), Address 00 / 00			
Program name	Service ID	Channel number	Channel selectable
MEGASPORT	0x0001	1	yes ▾
OTV	0x0002	2	no ▾
Reload Back Transmit			

Name of device, item number, module address in head end

On this page a channel number can be assigned each service. Its the number in all respective lists in the the receiver (such as Set-Top-Box) to find this service. Additionally in the column "Channel selectable" can be selected, whether the service is listed in the program list or not. E.g. for data services its meaningfully not to list them.

Network ID

adjustment range: 1 ... 999
0 ... service not enter in channel list

8.8 Software overview (menu 7)

COFDM MODULATOR, AMB 307 (9730.01 / 00), Address 00 / 00	
Version	
AP Controller	9730.01-81.01 Steuercontroller Anschluss-LP V1.00 10.06.2009 JR
FPGA Bootcontroller	9730.01-88.01 FPGA Boot Controller(1) V1.00 10.06.2009 JR
FPGA	9730.01-87.01 TS-Mux;COFDM-Modulator V1.00 09.06.2009 WE,JR
Nios	9730.01-90.01 TS-Manager V1.00 03.07.2009 JR
ASI-Bootcontroller	9850.02-88.01 FPGA Download Controller V1.35 08.09.2008 MF,PK
ASI-FPGA	9850.02-87.01 ASI Input FPGA V1.46 06.04.2009 WE,MF
Up Converter	9199.01-88.02 internal Controller V2.00 26.06.2008 JH
<input type="button" value="Back"/>	

Name of device, item number, module address in head end

Software version

Controller of terminals board

FPGA Bootcontroller

COFDM modulator, TS-Mux (FPGA)

TS manager

ASI Bootcontroller

ASI FPGA

Up Converter controller

8.9 Device status (menu 8)

COFDM MODULATOR, AMB 307 (9730.01 / 00), Address 00 / 00			
Input			
TS-Input	ASI 1	ASI 2	
Status	SYNC	no SYNC	
Data rate	38.015	0.000	Mbps
Packet size	188	---	Byte
FPGA-Status			
	Transport stream OK	No transport stream	
FPGA-Error memory	empty	empty	
Up Converter error memory	empty		
Original TS-ID's			
	TS-ID: 1 Network-ID: 4369	TS-ID: -- Network-ID: --	
Information			
Temperature		91 °F	
Device number		0000000	
Device index		00	
<input type="button" value="Reload"/> <input type="button" value="Back"/>			

Name of device, item number, module address in head end

Input

TS-Input displays 1 or 2 inputs acc. selected configuration
 Status **SYNC**hronisation or **noSYNC**hronisation with ASI input
 Data rate displays data rate of TS
 Packet size size of packets (188/ 204) in byte

FPGA Status

FPGA-Error memory status, transport stream input error memory TS Mux, COFDM Mod.
 Up Converter error memory error memory up converter

Original TS-ID's

display transport stream ID and network ID

Information

Temperature Temperature of terminals board
 Device number display of the device number
 Device index display of the device index (hardware)

8.10 Factory settings (menu 9)



When request this menu item at first a security query whether it really set all parameters to the factory default settings pops up.

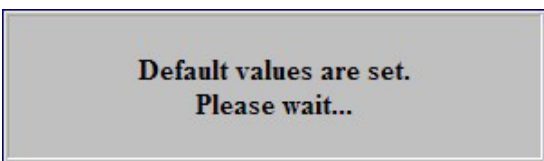

Affirming the query, all settings made on the EEPROM will be deleted and replaced by the default settings. The modul will go back to these default values. Once the setting process is over, there will be automatic return to the main menu. It takes about one minute.

9. Manual menu control with Headend Controller (HCB x00)

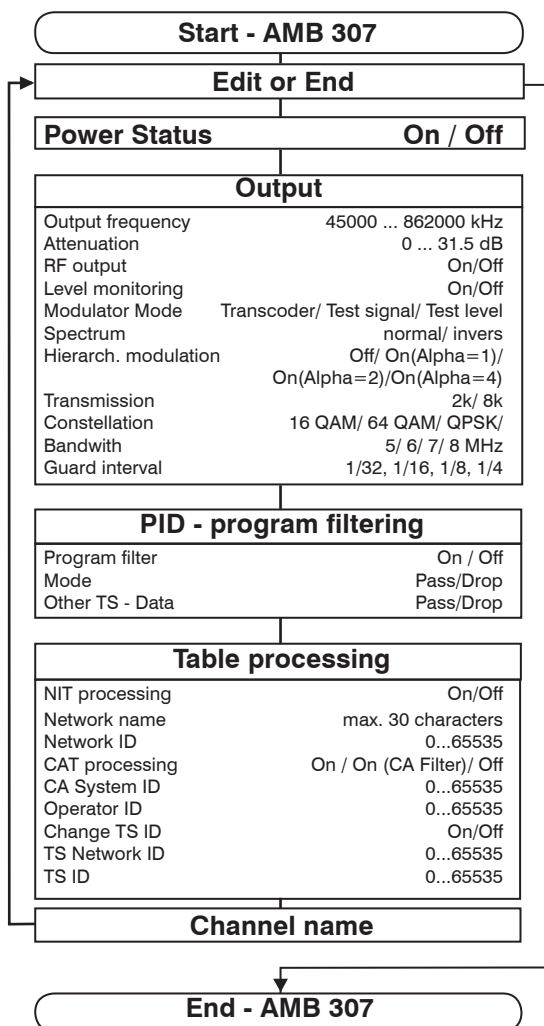

10. SNMP Trap Messages

Item	Message	Message Type	Explanation
01	Power fail	CRITICAL	short circuit
02	System Reset	WARNING	reset by internal error
03	Input OK	INFORMATION	module works correctly
04	Input not sync	WARNING	no ASI input signal
05	IIC error	CRITICAL	IIC-Bus-error
06	TS-MUX not sync	WARNING	no transport stream at the FPGA
07	Internal controller reset	WARNING	error when accessing internal controller
08	FPGA: Program memory full	WARNING	overflow of program memory in the FPGA
09	FPGA: PID memory full	WARNING	overflow of PID memory in the FPGA
10	FPGA: Directory full	WARNING	overflow of Directory in the FPGA
11	FPGA: FAT memory full	WARNING	overflow of FAT memory in the FPGA
12	FPGA: TS-Packed buffer overflow	WARNING	overflow of TS-Packet buffer
13	Data overflow	CRITICAL	overflow of data
14	Sync error data FIFO	CRITICAL	data FIFO doesn't work correctly
15	No response to OPEN command	CRITICAL	error internal port
16	FPGA ok	INFORMATION	data processing in FPGA is ok

Item	Message	Message Type	Explanation
17	Up Converter: PLL1 not locked	CRITICAL	no funktion at the PLL 1 converter
18	Up Converter: PLL2 not locked	CRITICAL	no funktion at the PLL 2 converter
19	Up Converter: IF input too small	WARNING	IF input too small at the Up converter
20	Up Converter: IF input too large	WARNING	IF input too large at the Up converter
21	Up Converter: RF output too small	WARNING	RF output too small at the Up converter
22	Up Converter: RF output too large	WARNING	RF output too large at the Up converter
23	Up Converter ok	INFORMATION	Up converter works correctly

11. Block diagram

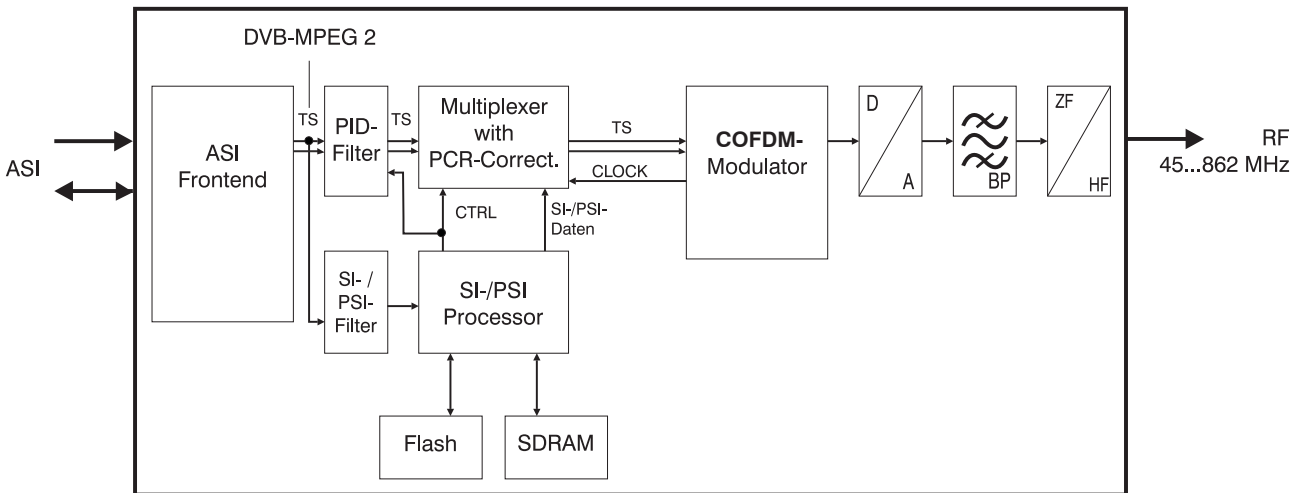

12. Head end bus structure

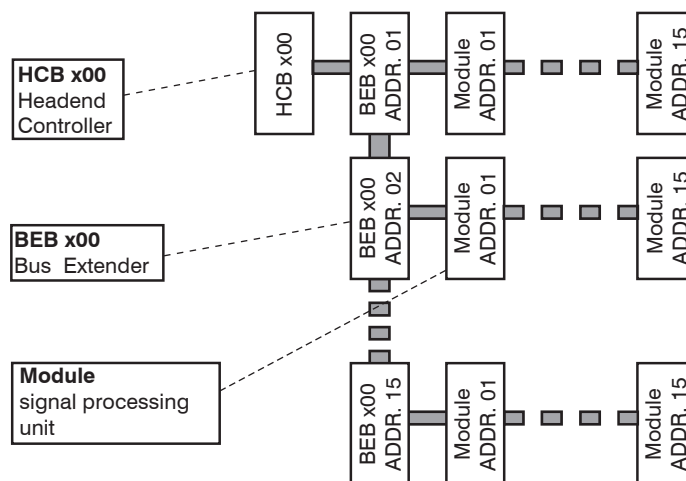

The number of the possible module connections (01 ... 15) to a BEB x00 depends on the total power consumption of this line!

13. Application example

Integration in existing B-LINE configuration

Conversion of 2 SAT transponders into 2xDVB-T

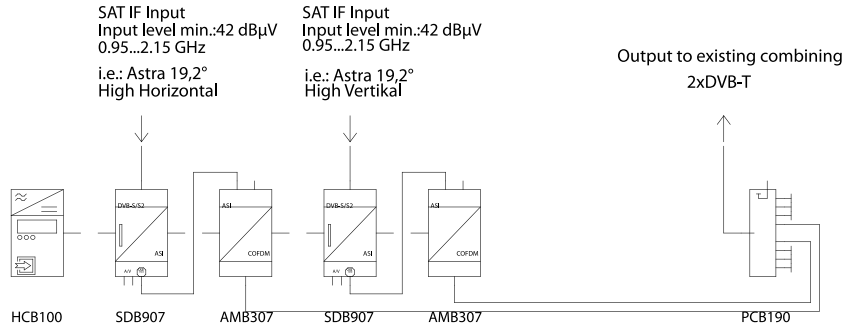

14. Technical data

ASI input

Level range	200 ... 880 mV _{pp}
System clock	270 Mbps
Connector	BNC socket
Impedance	75 Ω
ASI polarity	regular / inverted

ASI output

Level	800 mV _{pp} (± 10 %)
System clock	270 Mbps
Connector	BNC socket
Impedance	75 Ω
ASI polarity	regular

ASI signal processing

Data rate	0.625...213 Mbps
ASI transfer format	
Input	continuous, burst
Output	burst
TS transfer format	
Input	188, 204 Byte
Output	188, 204 Byte
Signal processing	EN 50083-9 [1]

COFDM Modulator

Transmission mode	2k, 8k
Guard interval	1/4, 1/8, 1/16, 1/32
Constellation	1/2, 2/3, 3/4, 5/6, 7/8
Hierarchical modulation	QPSK, 16 QAM, 64 QAM
Hierarchical protect mode	Alpha 1, 2, 4
Bandwith	5, 6, 7, 8 MHz

RF Output

Output frequency range	45 ... 862 MHz
Tuning step	10 kHz
Max. output level	115 dBµV
Level adjustment range	0 ... 31.5 dB (0.5 dB - steps)
Channel allocation	adjacent channel ability
Connector	F socket
Impedance	75 Ω
Return loss	≥ 18 dB 45 MHz - 1.5 dB / Octave

Signal quality

MER	≥ 43 dB
Shoulder attenuation	≥ 58 dB
Spurious 45...862 MHz	≥ 60 dB

C/N (> 25 MHz space from channel center)	
BW = 5 MHz	typ. 80 dB
BW = 8 MHz	typ. 78 dB
Phase noise	1 kHz; typ. -92 dBc/ Hz 10 kHz; typ. -101 dBc/ Hz 100 kHz; typ. -108 dBc/ Hz

max. Frequency stability	± 30 kHz
Output level stability	± 0.5 dB
Amplitude frequency response channel (8 MHz)	max. 1 dB _{pp}

Operating parameters

Voltage/ current	12 V (0.2 V)/ max. 650 mA
Residual ripple of the supply voltage	≤ 10 mV _{pp}

Environmental conditions

Temperature range	-10 ... +55 °C
Temperature range for data keeping	5 ... 45 °C
Relative humidity	≤ 80 % (non condensing)
Mounting method	vertical
Mounting location	splash-proof and drip-proof

Physical information

Dimensions (w x h x d)	
without 19" adapter	50 x 276 x 148 mm
with 19" adapter	50 x 301 x 148 mm
Weight	1,190 g

Delivery content

1 x Bus connector

15. Glossary

ASI	A synchronous S erial I nterface
AP	A nschlussplatte (front circuit board)
BW	B andwidth
CA	C onditional A ccess
CAT	C onditional A ccess T able
COFDM	C oded O rthogonal F requency D ivision M ultiplex
DVB	D igital V ideo B roadcasting (-C Cable, -S Satellit, -S2 Satellite 2, -T Terrestrial)
EIT	E vent I nformation T able
ETSI	E uropean T elecommunications S tandards I nstitute
FAT	F ile A llocation T able
FEC	F orward E rror C orrection
FIFO	F irst I n- F irst O ut
FPGA.....	F ield P rogrammable G ate A rray
HTML	H ypertext M arkup L anguage
HTTP	H ypertext T ransfer P rotocol
I/Q.....	I n-phase/ Q uadrature-phase
ID.....	I dentifier
IF	I ntermediate F requency
IIC.....	I nter- I ntegrated C ircuit (I ² C-Bus, data bus within device)
IP.....	I nternet P rotocol
LED	L ight E mitting D iode
MAC	M edia A ccess C ontrol
MER	M odulation E rror R atio
MIB.....	M anagement I nformation B ase
MPEG.....	M oving P icture E xperts G roup
NIM	N etwork I nterface M odule
Nios.....	product name for a processor
NIT	N etwork I nformation T able
PAT.....	P rogram A ssociation T able
PCR.....	P rogram C lock R eference
PID	P rogram I dentifier
PMT.....	P rogram M ap T able
PSI	P rogram S ervice I nformation
QAM.....	Q uadrature A mplitude M odulation
QPSK.....	Q uadrature P hase S hift K eying
RF	R adio F requency
SDT	S ervice D escription T able
SI.....	S ervice I nformation
SNMP.....	S ingle N etwork M anagement P rotocol
TS.....	T ransport s tream

16. Bibliography

- [1] EN 50083-9: Cabled distribution systems for television, sound and interactive multimedia signals, part 9: Interfaces for CATV/SMATV head ends and similar professional equipment for DVB/MPEG-2 transport streams
- [2] EN 60728-11: Cable networks for television signals, sound signals and interactive services Part 11: Safety (IEC 60728-11:2005); German version EN 60728-11:2005
- [3] RFC 1157 Request for Comments (RFC): RFC Database URL: [Http://www.rfc-editor.org/rfc.html](http://www.rfc-editor.org/rfc.html)
- [4] EN 50083-2 : Cabled distribution systems for television and sound signals. Electromagnetic compatibility for equipment; EN 50083-2:2001

17. Document history

Version	Date	Modification	Author
1.00	25.07.2009	basic dokument	Häußer

Options and other TV standards available upon request! Subjects to changes due to technical progress.

Declaration of Conformity

The Manufacturer

BLANKOM Antennentechnik GmbH · Hermann-Petersilge-Str. 1 · 07422 Bad Blankenburg · Germany

herewith declares the conformity of the product

Product name: COFDM Modulator

Type: AMB 307

Product number: 9730.01

according to the following regulations

EN 50083-2

EN 60728-11 (as far as relevant)

and additional device-specific regulations, enclosed above, which this product is subjected to.

Date: 25.07.2009

Signature:



(Managing Director)