

ADB 209

ASI - TS - DEMODULATOR

ASI - TS CI ASI-TS & A/V

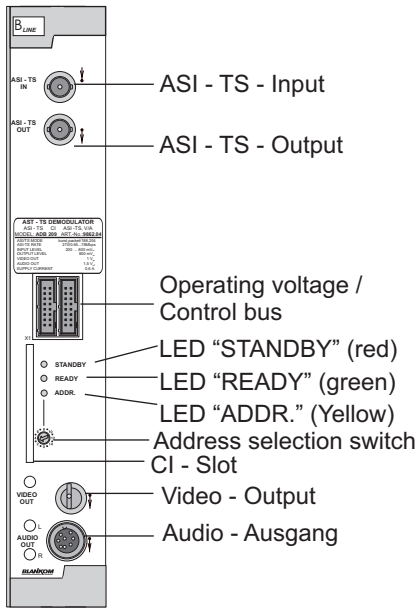

Fig. 01

DEVICE VARIANTS

ADB 209 9862.05 ASI-Transport stream into ASI-Transport stream with CI (Common Interface)
2 x Audio/Video with CI (Common Interface)

Minimum software requirements for HCB 100 (Headend Controller)

9650.03: > V 2.24
9650.04: > V 3.00

GENERAL

The ASI - TS Demodulator ADB 209 is a module of the headend system B-LINE which is conceived as a complete system for middle sized networks. The ADB 209 converts one program (selected from a transport stream) into one analogue Audio- & Video signal. The device has a Common-Interface slot for CA-Modules. It supports decoding of one program/service but also "Multi-Service-Decryption"*. It is therefore possible to decrypt one or more programs/services. The decrypted program/service is then available at the ASI-output.

All modules can be programmed via the central control unit (HCB100) and are working independently afterwards.

The status of each module will be displayed via colored LED's

Red - STANDBY Standby mode

FUNCTION DESCRIPTION

The digital ASI - signal will be decoded. The received serial datastream will be parallelised and fed to a FIFO. The data beat will be regenerated from the level of the FIFO. Following to the FIFO the regeneration of the transport stream-SPI protocol takes place. The detection of a correct transport stream happens simultaneously. The datastream will be fed to by a switch matrix either via the Common Interface or directly via the DVB-module (consisting of demultiplexer and MPEG-Decoder). The decoded transportstream at the ASI-output can be took off simultaneously. An analogue Video- and a related digital stereo Audio signal will be still generated within the DVB-module. Afterwards, the video signal will be filtered and the audio signal converted digital/analogue. The analogue signals will be fed to the outputs of the module via isolation amplifiers (Allocation audio socket / Fig. 06). The module consists of a standardized CI-slot for Conditional-Access-modules (CA-modules). A respective system related CA-module has to be used for decoding (Cryptoworks, Irdeto, Viaccess, ...)

* The used CA-Module has to support Multi-Service-Decryption

Additional functions: CA - module - voltage (Fig. 04)

PROGRAMMING

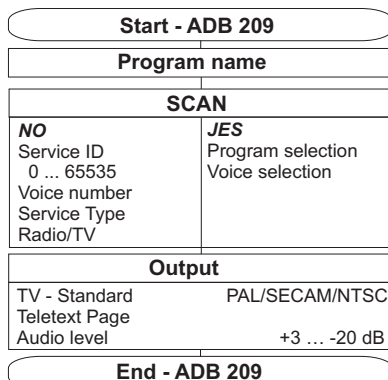

Fig. 02

Adjustment with the headend controller

Adjustment of the addresses at the bus extender BEB 100 and at the modules

Activation of the programming mode of each module by selecting the line (BEB 100) and the module position (01... 15) at the head end controller(HCB 100)

yellow LED will be lit up til the beginning of the parameter adjustment

Adjustment of the ADB 209 parameter(see fig.02)

green LED is lit up

After the programming the ADB 209 will be automatically switched into the operating status

yellow LED lights up briefly / green LED is lit up

Adjustment with the PC / Laptop

Condition for the remote programming is an "online - connection" after IP - standard and an ethernet connection at the PC / Laptop

Adjustment of the line / position addresses at the bus extender BEB 100 as well as at the modules

At the head end controller HCB 100 IP - address input (e.g. 192.168.001.001)

For "direct connection" between a PC and HCB 100 use a crossed patch cable (RJ 45)

For connection over a deviation use an uncrossed patch cable

HTML - browser start-up and put in IP - address as target address

If connected correctly the HTML - control surface at the PC will open up and a green LED (LINK) at the HCB 100 will be lit up

All adjustment of the modules are specified at the control surface

a green LED (LINK) at the HCB 100 will be lit up

All adjustment of the modules are specified at the control surface

The manual instructions of the headend controller HCB 100 and the bus extender BEB 100 have to be considered!

TECHNICAL DATAS

ASI - Input

Level range	200 ... 800 mV _{ss}
Data rate	270 Mbit/s
Connector	BNC - socket
Impedance	75
ASI-Polarity	normal / negated

ASI - Output

ASI-Data rate	270 Mbit/s
ASI-Mode	continuous
ASI-Polarity	normal / negated
TS-Data rate	corresponding to input
TS-Mode	corresponding to input
Output level	800mVpp (+/- 10%)
Connector	BNC - socket
Impedance	75

ASI - Signal processing

Data rate	0.625 ... 78 Mbit/s
ASI - Transmission format (input)	Burst, Packet
TS - Transmission format (input)	188, 204
Signal processing	EN 50083-9

Decoding - Interface

Common Interface	PCMCIA - Slot according to EN 50221
Operating voltage (plugable)	+5 V / +3,3 V

Video - Output

Output voltage	1 V _{ss}
Impedance	75
Connector	BNC - socket
TV - standards	PAL / SECAM / NTSC

Audio - Output

Nominal Level	6 dBu at 10 k
at (digital 0 dBFS)	4dBm at 600
Output	symmetrical floating
Output impedance	30
Connector	1 x Socket according to DIN 45326/ IEC 130 - 9 - 20 2 x MCX socket

Operating parameter

Voltage / Current	12 V (0,2 V) / 600 mA
Residual ripple of supply voltage	10 mV _{ss}

Environmental conditions

Temperature range	-10 ... +55 °C
Relative humidity	80 % (not condens.)
Mounting method	vertical
Mounting location	squirting- & dripping water protected / Dry

Physical information

Dimensions (W x H x L)	50 x 276 x 148 mm
without 19" - Adapter	50 x 301 x 148 mm
with 19" - Adapter	Weight
Weight	1235 g

Delivery content

1 x BUS - connector
1 x Audio cable ASK 525
1 x Video cable VVK 526
3 x MCX BNC cable

HEADEND BUS - STRUCTURE

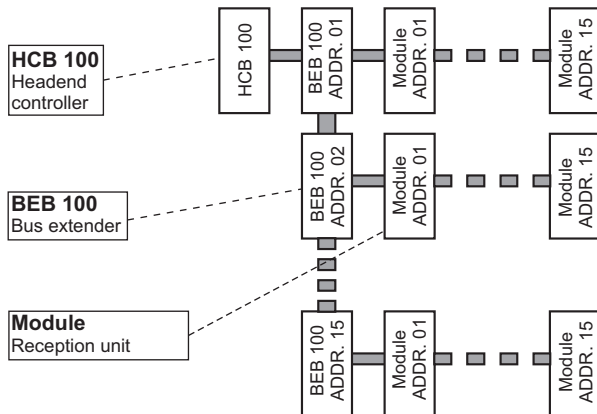

The number of the possible module connections (00 ... 15) to a BEB 100 depends on the total power consumption of this line!

Fig. 03

SPECIAL FUNCTIONS

Allocation of the Audio - socket

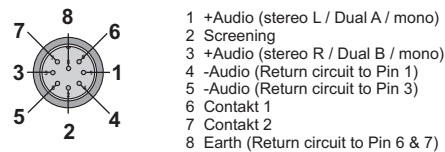

Audiomode	Contact 1 Pin 6 - 8	Contact 2 Pin 7 - 8
Mono	Offen	Closed
Stereo	Closed	Open
Dual	Closed	Closed

Fig. 04

SECURITY AND OPERATING INSTRUCTIONS

- When assembling, starting-up and adjusting the modules, it is necessary to consider the system specific references in the manual instruction!
- The modules may only be installed and started up by authorized technical personnel!
- When assembling the modules into the receiving points, the adherence of the EMV regulations is to be secured!
- The assembly and wiring have to be done without voltage!
- All active modules may only be operated with the head end controller HCB 100 or bus extender BEB 100!
- The main voltage for all power supply units is 230 V, 50 Hz.
- With all work the defaults of the DIN EN 50083 have to be considered!
Especially the safety relevant execution of the DIN EN 50083/1 is necessary!



Options and other TV standards available upon request!

Changes due to technical progress possible.

Part n°: 9862.05

BLANKOM Antennentechnik GmbH

Hermann - Petersilge - Str. 1 07422 Bad Blankenburg Germany Phone +49 (0) 36741/ 60-0 Fax +49 (0) 36741/ 60-100