



**Digital Video Broadcasting (DVB); Framing  
Structure, channel coding and modulation for  
Satellite Services to Handheld devices (DVB-SH)  
below 3 GHz  
(dEN 302 583 V1.1.3)**

**DVB Document A111  
June 2010**



---

# Contents

Intellectual Property Rights .....	5
Foreword.....	5
1 Scope .....	6
2 References .....	6
2.1 Normative references .....	7
2.2 Informative references .....	7
3 Definitions, symbols and abbreviations .....	7
3.1 Definitions .....	7
3.2 Symbols .....	8
3.3 Abbreviations.....	8
4 Transmission system description.....	9
4.1 System definition .....	9
4.2 System architecture.....	9
5 Subsystems specification.....	10
5.1 Mode adaptation .....	10
5.1.1 CRC-16 encoder.....	11
5.1.2 Encapsulation Frame Header insertion.....	12
5.2 Stream adaptation .....	13
5.2.1 Padding.....	13
5.2.2 EScrambling.....	13
5.3 FEC encoding and channel interleaving .....	14
5.3.1 Constituent codes of the turbo encoder and puncturing patterns.....	14
5.3.2 Turbo code termination .....	16
5.3.3 Turbo interleavers .....	17
5.4 Channel interleaver and rate adaptation.....	19
5.4.1 Overview .....	19
5.4.2 Bit-wise interleaving and rate adaptation .....	19
5.4.3 Time interleaver .....	21
5.5 Frame structure .....	22
5.5.1 Interface with FEC encoding.....	22
5.5.2 SH Frame structure .....	22
5.5.2.1 Overview .....	22
5.5.2.2 Elementary parts description .....	25
5.5.2.3 OFDM mode.....	26
5.5.2.4 TDM mode .....	28
5.5.3 Interface with modulation .....	28
5.6 Single carrier (TDM) .....	28
5.6.1 Interface to SH frame .....	28
5.6.2 Bit mapping into constellation .....	29
5.6.2.1 Bit mapping into QPSK constellation.....	29
5.6.2.2 Bit mapping into 8PSK constellation .....	30
5.6.2.3 Bit mapping into 16APSK constellation.....	30
5.6.3 TDM symbol rate selection .....	31
5.6.4 TDM framing .....	31
5.6.4.1 PL Slot definition .....	31
5.6.4.2 Pilot insertion.....	32
5.6.4.3 Physical layer scrambling.....	33
5.6.5 Baseband shaping and quadrature modulation .....	34
5.7 Multi carrier (OFDM).....	35
5.7.1 Interface to SH frame .....	35
5.7.1.1 CU mapping.....	35
5.7.1.2 Bit demultiplexing .....	35
5.7.2 Symbol interleaver .....	36

5.7.3	Bit mapping into constellation .....	39
5.7.4	OFDM framing.....	41
5.7.4.1	OFDM frame structure .....	41
5.7.4.2	Reference signals.....	45
5.7.4.2.1	Functions and derivation.....	45
5.7.4.2.2	Definition of reference sequence .....	45
5.7.4.2.3	Location of scattered pilot cells .....	46
5.7.4.2.4	Location of continual pilot carriers.....	46
5.7.4.2.5	Amplitudes of all reference information.....	48
5.7.4.3	Transmission Parameter Signalling (TPS).....	48
5.7.4.3.1	Scope of the TPS.....	49
5.7.4.3.2	TPS transmission format.....	49
5.7.4.3.3	TPS modulation .....	54
5.7.5	Baseband shaping and quadrature modulation .....	55
Annex A (normative):    SH frame Initialization Packet (SHIP) .....		56
A.1	Introduction.....	56
A.2	SHIP header .....	56
A.3	Mandatory parameters.....	57
A.4	Optional SHIP section parameters .....	58
A.4.1	Transmitter time offset function .....	59
A.4.2	Transmitter frequency offset function.....	59
A.4.3	Transmitter power function.....	60
A.4.4	Private data function .....	60
A.4.5	Cell id function .....	60
A.4.6	Enable function.....	61
A.4.7	Bandwidth function.....	61
A.4.8	Service localization function.....	61
A.4.9	Service synchronization function.....	62
A.4.10	TDM function .....	63
A.4.11	Group membership function .....	64
A.5	CRC decoder model .....	65
Annex B (informative):    Bibliography.....		67
History .....		68

---

## Intellectual Property Rights

IPRs essential or potentially essential to the present document may have been declared to ETSI. The information pertaining to these essential IPRs, if any, is publicly available for ETSI members and non-members, and can be found in ETSI SR 000 314: "*Intellectual Property Rights (IPRs); Essential, or potentially Essential, IPRs notified to ETSI in respect of ETSI standards*", which is available from the ETSI Secretariat. Latest updates are available on the ETSI Web server (<http://webapp.etsi.org/IPR/home.asp>).

Pursuant to the ETSI IPR Policy, no investigation, including IPR searches, has been carried out by ETSI. No guarantee can be given as to the existence of other IPRs not referenced in ETSI SR 000 314 (or the updates on the ETSI Web server) which are, or may be, or may become, essential to the present document.

---

## Foreword

This European Standard (Telecommunications series) has been produced by Joint Technical Committee (JTC) Broadcast of the European Broadcasting Union (EBU), Comité Européen de Normalisation ELEctrotechnique (CENELEC) and the European Telecommunications Standards Institute (ETSI).

The work of the JTC was based on the studies carried out by the European DVB Project under the auspices of the Ad Hoc Group on DVB-SH of the DVB Technical Module. This joint group of industry, operators and broadcasters provided the necessary information on all relevant technical matters (see bibliography).

NOTE: The EBU/ETSI JTC Broadcast was established in 1990 to co-ordinate the drafting of standards in the specific field of broadcasting and related fields. Since 1995 the JTC Broadcast became a tripartite body by including in the Memorandum of Understanding also CENELEC, which is responsible for the standardization of radio and television receivers. The EBU is a professional association of broadcasting organizations whose work includes the co-ordination of its members' activities in the technical, legal, programme-making and programme-exchange domains. The EBU has active members in about 60 countries in the European broadcasting area; its headquarters is in Geneva.

European Broadcasting Union  
 CH-1218 GRAND SACONNEX (Geneva)  
 Switzerland  
 Tel: +41 22 717 21 11  
 Fax: +41 22 717 24 81

Founded in September 1993, the DVB Project is a market-led consortium of public and private sector organizations in the television industry. Its aim is to establish the framework for the introduction of MPEG-2 based digital television services. Now comprising over 200 organizations from more than 25 countries around the world, DVB fosters market-led systems, which meet the real needs, and economic circumstances, of the consumer electronics and the broadcast industry.

National transposition dates	
Date of adoption of this EN:	14 March 2008
Date of latest announcement of this EN (doa):	30 June 2008
Date of latest publication of new National Standard or endorsement of this EN (dop/e):	31 December 2008
Date of withdrawal of any conflicting National Standard (dow):	31 December 2008

---

# 1 Scope

The present document specifies a transmission system for hybrid satellite and terrestrial digital television broadcasting to mobile terminals. It is derived from the DVB-T [1] and DVB-H [6] system specification, respectively designed for digital television terrestrial broadcasting towards fixed and mobile terminals and DVB-S2, [2] designed for digital satellite broadcasting towards fixed terminals. The purpose of the DVB-SH standard is to provide an efficient transmission system using frequencies below 3 GHz suitable for Satellite Services to Handheld devices, in terms of reception threshold and resistance to mobile satellite channel impairments.

The system relies on a hybrid satellite/terrestrial infrastructure. The signals are broadcast to mobile terminals on two paths:

- A direct path from a broadcast station to the terminals via the satellite.
- An indirect path from a broadcast station to terminals via terrestrial repeaters that form the Complementary Ground Component (CGC) to the satellite. The CGC can be fed through satellite and/or terrestrial distribution networks.

The system includes two transmission modes:

- An OFDM mode based on DVB-T standard [1] with enhancements. This mode can be used on both the direct and indirect paths; the two signals are combined in the receiver to strengthen the reception in a SFN configuration.
- A TDM mode partly derived from DVB-S2 standard [2], in order to optimize transmission through satellite towards mobile terminals. This mode is used on the direct path only. The system supports code diversity recombination between satellite TDM and terrestrial OFDM modes so as to increase the robustness of the transmission in relevant areas (mainly suburban).

The present document specifies the digital signal format and the digital signal modulation and coding in order to allow compatibility between pieces of equipment developed by different manufacturers. Signal processing at the modulator side is described in details, while processing at receiver side is left open to a particular implementation (as far as it complies with the present document).

---

# 2 References

References are either specific (identified by date of publication and/or edition number or version number) or non-specific.

- For a specific reference, subsequent revisions do not apply.
- Non-specific reference may be made only to a complete document or a part thereof and only in the following cases:
  - if it is accepted that it will be possible to use all future changes of the referenced document for the purposes of the referring document;
  - for informative references.

Referenced documents which are not found to be publicly available in the expected location might be found at <http://docbox.etsi.org/Reference>.

For online referenced documents, information sufficient to identify and locate the source shall be provided. Preferably, the primary source of the referenced document should be cited, in order to ensure traceability. Furthermore, the reference should, as far as possible, remain valid for the expected life of the document. The reference shall include the method of access to the referenced document and the full network address, with the same punctuation and use of upper case and lower case letters.

NOTE: While any hyperlinks included in this clause were valid at the time of publication ETSI cannot guarantee their long term validity.

## 2.1 Normative references

The following referenced documents are indispensable for the application of the present document. For dated references, only the edition cited applies. For non-specific references, the latest edition of the referenced document (including any amendments) applies.

- [1] ETSI EN 300 744: "Digital Video Broadcasting (DVB); Framing structure, channel coding and modulation for digital terrestrial television".
- [2] ETSI EN 302 307: "Digital Video Broadcasting (DVB); Second generation framing structure, channel coding and modulation systems for Broadcasting, Interactive Services, News Gathering and other broadband satellite applications".
- [3] 3GPP2 C.S0002-D, September 2005: "3GPP2: Physical Layer Standard for cdma2000 Spread Spectrum Systems, Revision D".

NOTE: See [http://www.3gpp2.org/Public\\_html/specs/C.S0002-D\\_v2.0\\_051006.pdf](http://www.3gpp2.org/Public_html/specs/C.S0002-D_v2.0_051006.pdf).

- [4] ISO/IEC 13818-1: "Information technology - Generic coding of moving pictures and associated audio information: Systems".
- [5] ETSI EN 301 192: "Digital Video Broadcasting (DVB); DVB specification for data broadcasting".
- [6] ETSI EN 302 304: "Digital Video Broadcasting (DVB); Transmission System for Handheld Terminals (DVB-H)".
- [7] ETSI TS 102 606: "Digital Video Broadcasting (DVB); Generic Stream Encapsulation (GSE) Protocol".
- [8] Void.
- [9] ETSI TS 102 585: "Digital Video Broadcasting (DVB); System Specifications for Satellite services to Handheld devices (SH) below 3 GHz".
- [10] ETSI EN 300 468: "Digital Video Broadcasting (DVB); Specification for Service Information (SI) in DVB systems".

## 2.2 Informative references

Not applicable.

---

# 3 Definitions, symbols and abbreviations

## 3.1 Definitions

For the purposes of the present document, the following terms and definitions apply:

**class 1 receiver:** support short physical layer protection in the order of one DVB-H burst

NOTE: As defined in [9].

**class 2 receivers:** support long physical layer protection in the order of several DVB-H bursts

NOTE: As defined in [9].

**code combining:** transmission and decoding technique consisting in transmitting complementary or partially complementary components of a mother code through different channels (in SH-B systems, using satellite TDM and terrestrial OFDM) and recombining the punctured parts into a single coded FEC block before decoding

SH-A architecture: DVB-SH system using OFDM on the satellite path

NOTE: As defined in [9].

SH-B architecture: DVB-SH system using TDM on the satellite path

NOTE: As defined in [9].

## 3.2 Symbols

For the purposes of the present document, the following symbols apply:

$L_{TC-input}$	Turbo Code input block length in bits
$q'$	Symbol Number

## 3.3 Abbreviations

For the purposes of the present document, the following abbreviations apply:

BCH	Bose, Ray-Chaudhuri, Hocquenghem
CGC	Complementary Ground Component
CR	Code Rate
CRC	Cyclic Redundancy Check
CU	Capacity Unit

NOTE: Defined as a block of 2 016 bits.

D	Decimal notation
DFL	DATAFIELD Length
DVB	Digital Video Broadcasting project
DVB-H	Digital Video Broadcasting for Handheld terminals
DVB-S	Digital Video Broadcasting for Satellite services
DVB-S2	DVB-S, second generation
DVB-T	Digital Video Broadcasting for Terrestrial services
EBU	European Broadcasting Union
EFRAME	Encapsulation Frame
EHEADER	Encapsulation Frame Header
EN	European Norm
EXOR	Exclusive OR function
FEC	Forward Error Correction
FFT	Fast Fourier Transform
FIFO	First In First Out
GF	Galois Field
ISI	Input Stream Identifier
IU	Interleaver Unit

NOTE: Defined as a set of 126 bits.

LSB	Least Significant Bit
MIP	Mega-frame Initialization Packet
MPE	Multi-Protocol Encapsulation
MPEG	Moving Pictures Experts Group
MPEG-TS	MPEG-Transport Stream
MSB	Most Significant Bit
$N_{BIL}$	Number of bits at the output of the bit interleaver
NCW	Number of Coded words
$N_{TCB}$	Number of bits of the FEC (turbo) coded block
OFDM	Orthogonal Frequency Division Multiplexing
PER	(MPEG TS) Packet Error Rate
PID	Packet IDentifier
PL	Physical Layer

PRBS	Pseudo Random Binary Sequence
PSK	Phase Shift Keying
QAM	Quadrature Amplitude Modulation
QPSK	Quaternary Phase Shift Keying
RF	Radio Frequency
RFU	Reserved for Future Use
NOTE:	when appended with 'bit', 'RFU bits' refers to a sequence of bits all equal to '0'.
RSC	Recursive Systematic Convolutional Coder
SF	Signalling Field (inserted in TDM mode)
SFN	Single Frequency Network
SH	Satellite to Handheld
SHIP	SH frame Initialization Packet
SHL	SH frame Length (variable in TDM mode)
SL	Service Layer
SOF	Start Of Frame (inserted in TDM mode)
SYNC	User packet SYNChronization byte
EXAMPLE:	0x47 for MPEG packets.
TDM	Time Division Multiplex
TS	Transport Stream
UP	User Packet
UPL	User Packet Length

## 4 Transmission system description

### 4.1 System definition

The system is mainly designed to transport mobile TV services. It may also support a wide range of mobile multimedia services, e.g. audio and data broadcast as well as file download services.

The system performs the adaptation and transmission of one or two (in case of hierarchical mode) baseband signals to both satellite and terrestrial channel characteristics. Baseband signals at system input are, by default, MPEG Transport Streams (MPEG-TS, see [4]) and are composed of bursts compliant with DVB-H time slicing [5]. Typically a burst transports a given service (or set of services), e.g. a TV channel. The size of each burst may vary with time in order to support Variable burst Bit Rate.

The present document applies to the MPEG-TS format but the support of a Generic Stream is not precluded (see clause 5.1).

### 4.2 System architecture

Figure 4.1 describes the transmission system. It includes two modulation possibilities for the satellite path: an OFDM mode based on DVB-T standard and a TDM mode, partly derived from DVB-S2 structure.

The following process, composed of a part common to both modes, and parts dedicated to each mode, shall be applied to the input stream(s):

Both modes:

- Mode adaptation: CRC-16 and insertion of the Encapsulation Frame Header.
- Stream adaptation: padding and scrambling of the Encapsulation Frame.
- Forward Error Correction (FEC) encoding using 3GPP2 [3] turbo code.
- Bit-wise interleaving applying on a FEC block. The latter is meanwhile shortened to comply with the modulation frame structure of OFDM and TDM.
- Convolutional time interleaving and framing.

TDM mode:

- Bit mapping to the constellation.
- TDM physical layer framing.
- Pilots insertion and scrambling.
- Pulse shaping and quadrature modulation.

OFDM mode:

- Symbol interleaver.
- Bit mapping to the constellation.
- OFDM framing with pilots and TPS insertion.

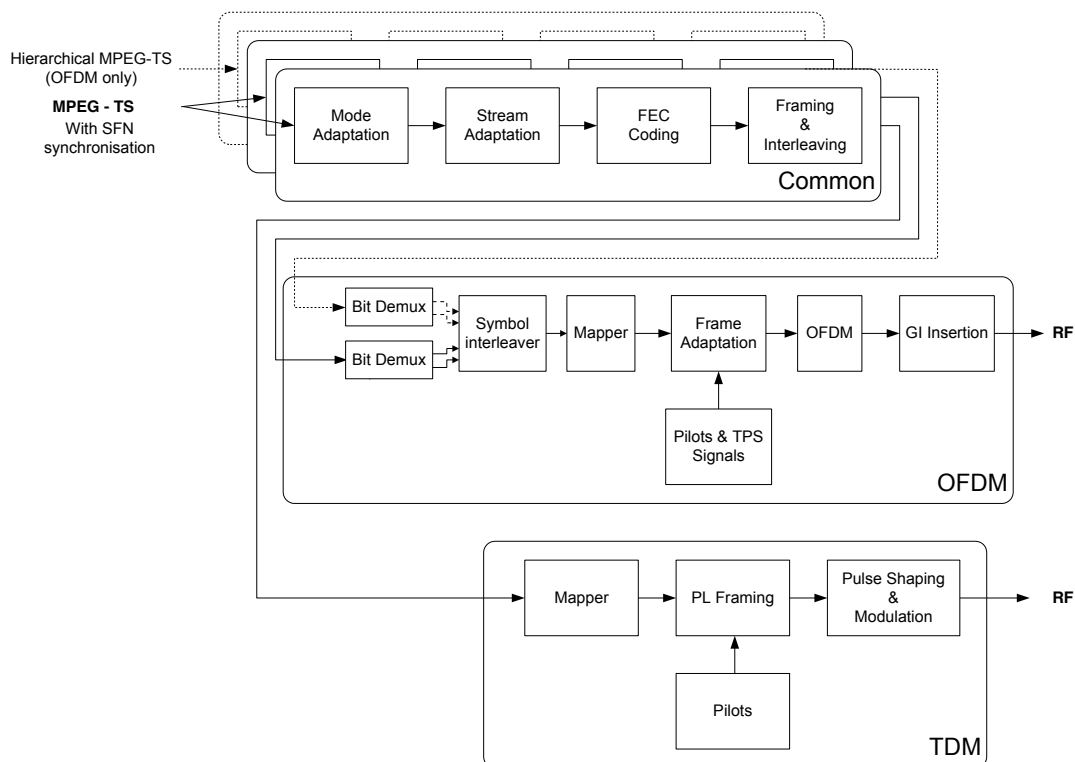

**Figure 4.1: Functional block diagram of the DVB-SH transmitter (Either TDM or OFDM configurations)**

## 5 Subsystems specification

### 5.1 Mode adaptation

Figure 5.1 gives the functional block diagram of the mode adaptation. It consists of CRC encoding, to provide error detection on every MPEG packet, and of inserting an Encapsulation Signalling (ESignalling). Even if the current version of the air interface fully supports only MPEG-TS input stream, mode adaptation is already able to handle any input stream format, be it packetized or not. The ESignalling process (thanks to the EHEADER structure, see clause 5.1.2) straightforwardly ensures this full compliance.

The output of mode adaptation is composed of an EHEADER followed by a DATAFIELD.

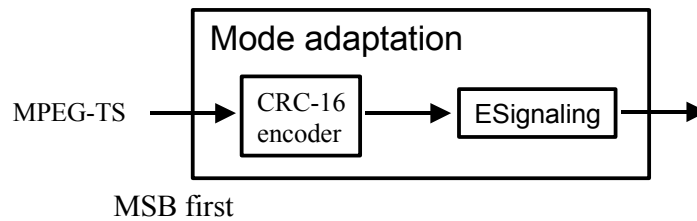

**Figure 5.1: Functional block diagram of the mode adaptation**

An MPEG Transport Stream corresponds to User Packets (UP) of constant length  $UPL = 188 \times 8_D$  bits (one MPEG packet), the first byte being a Sync-Byte (47HEX). A DATAFIELD is designed so as to contain exactly 8 MPEG packets.

The DATAFIELD has an index related to the SH Frame.

### 5.1.1 CRC-16 encoder

CRC-16 encoding provides error detection capability to upper layers. The input stream is a sequence of User Packets of length UPL bits ( $UPL = 188$  bytes), starting with a Sync-Byte.

The useful part of the UP (excluding the Sync-Byte) shall be processed by a systematic 16-bit CRC encoder. The generator polynomial shall be  $0x1021$ :

$$g(X) = X^{16} + X^{12} + X^5 + 1$$

The CRC encoder output shall be computed as:

$$\text{CRC} = \text{remainder}[X^{16} u(X) : g(X)]$$

with  $u(X)$  being the input sequence ( $UPL - 8$  bits) to be systematically encoded. The generator  $g(X)$  shall be initialized with the sequence  $0xFFFF$ . The computed CRC-16 shall be placed at the end of the current User Packet, and the SYNC-Byte shall be removed, as shown on figure 5.2. As described in clause 5.1.2, the Sync-Byte is copied into the SYNC field of the EHEADER for transmission.

The DATAFIELD is composed of a set of 8 UPs with their CRC-16.

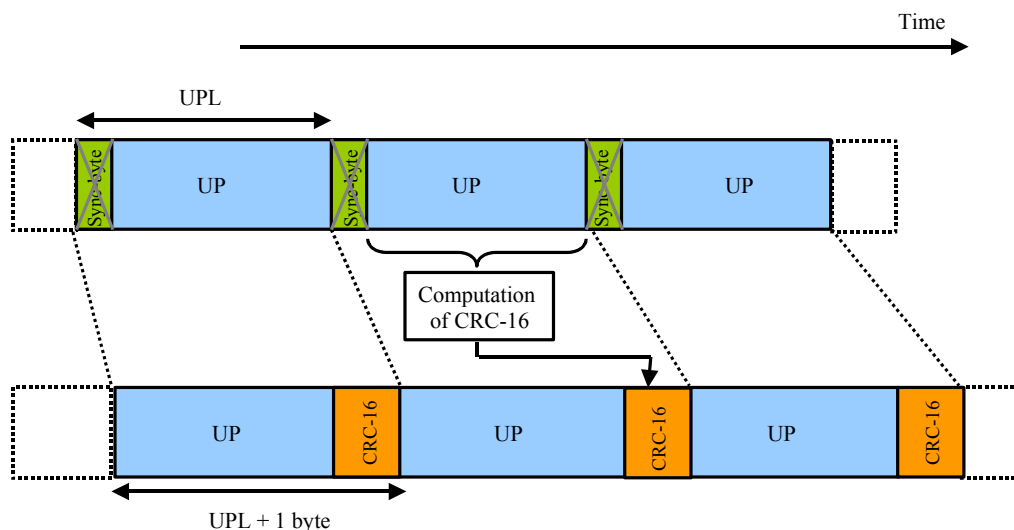

**Figure 5.2: Illustration of the CRC-16 encoding process**

## 5.1.2 Encapsulation Frame Header insertion

A fixed length Encapsulation Frame Header (EHEADER) of 114 bits shall be inserted in front of the DATAFIELD (see figure 5.3). The EHEADER aims at signalling the input stream features and supporting the code diversity. First field of EHEADER is devoted to support other input stream formats than MPEG-TS. Value 01 is devoted to a data stream encapsulated according to Generic Stream Encapsulation protocol as defined in [7]. The format of the EHEADER is the following (see also figure 5.3):

- TIS (2 bits): Type of Input Stream according to table 5.1.

**Table 5.1: TIS mapping field**

TIS	Description
11	[MPEG-TS]
10	[reserved]
01	[Generic Stream]
00	[reserved]

- UPL (16 bits): User Packet length in bits.
  - $UPL = 188 \times 8_D$  for MPEG-TS.
- DFL (16 bits): DATAFIELD Length in bits.
  - DFL = 12 096 bits for MPEG-TS.
- SYNC (8 bits): copy of the User Packet Sync-Byte (identical for all packets).
- RFU (32 bits): RFU bits to support future additional features.
- CBCOUNTER (24 bits): this field identifies the FEC block position index, hence enabling supports of code diversity through tagging of each EFRAME/FEC codeword. It is split into two parts:
  - CBCOUNTER\_SH (msb 14 bits): two cases are possible depending on the SHIP service synchronization function (please refer to clause A.4.9):
    - If service synchronization is not present on this transmitter, all bits are set to 0.
    - If service synchronization is present on this transmitter, it indicates the number of the SH frame inside the frame multiplexing (first SH frame), it is incremented by 1 every SH frame that has no start of service 0, it is reset to 0 at each SH frame having a service 0 start.
  - CBCOUNTER\_FB (lsb 10 bits):
    - Indicates position index of the EFRAME/FEC block inside current SH frame, first position being coded as 0 (zero).
    - Incremented by 1 every EFRAME.
    - Reset to 0 at each SH frame start.
- CRC-16 (16 bits): error detection code applied to the first 98 bits of the EHEADER. CRC-16 shall be computed using the same way as defined in clause 5.1.1.

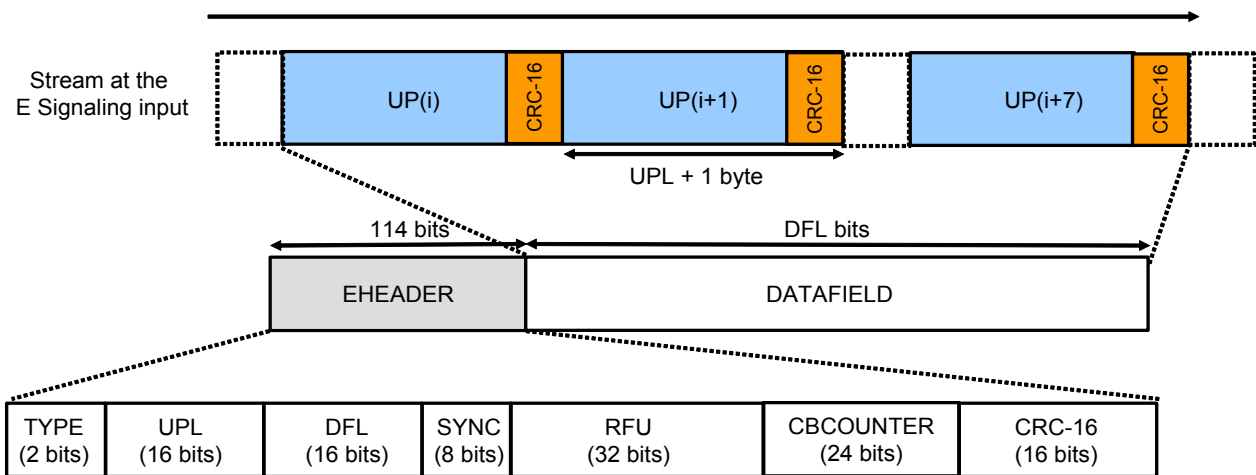

Figure 5.3: Description of the ESignalling process

## 5.2 Stream adaptation

Stream adaptation (see figures 5.4 and 5.5) provides padding to complete a constant length ( $L_{TC-input} = 12\,282$  bits) Encapsulation Frame (EFRAME) and performs scrambling. EFRAME is designed so as to match the input turbo code block size, namely  $L_{TC-input} = 12\,282$  bits, independently of the code rate.

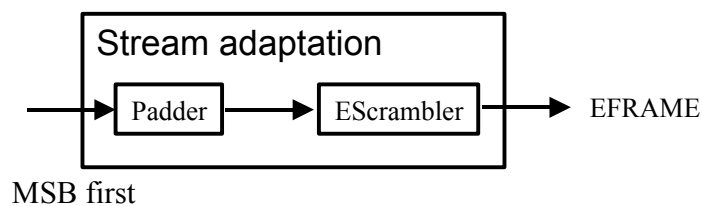

Figure 5.4: Functional block diagram of the stream adaptation

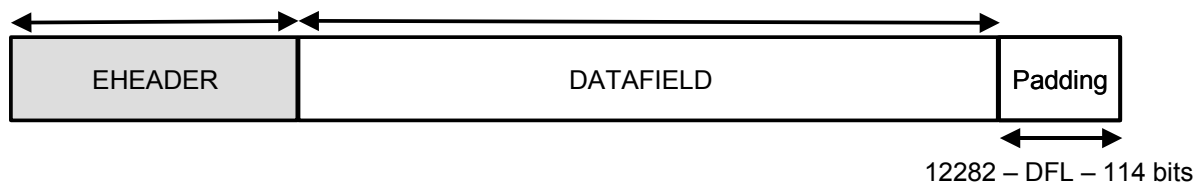

Figure 5.5: EFRAME format at the output of stream adaptation

### 5.2.1 Padding

In DVB-SH system,  $(12\,282 - DFL - 114)$  bits of zero bits shall be appended after the DATAFIELD. The resulting EFRAME shall have a constant length of  $L_{TC-input}$  bits, namely  $12\,282$  bits.

For MPEG-TS,  $DFL = 8 \times (187 + 2) \times 8 = 12\,096$  bits. Therefore 72 bits (9 bytes) of padding are required.

### 5.2.2 EScrambling

The complete EFRAME shall be randomized. The randomization sequence shall be synchronous with the EFRAME, starting from the MSB and ending after  $L_{TC-input}$  bits.

The scrambling sequence shall be generated by the feedback shift register of figure 5.6. The polynomial for the Pseudo Random Binary Sequence (PRBS) generator shall be:

$$1 + X^{14} + X^{15}$$

Loading of the sequence (10010101000000) into the PRBS register, as indicated in figure 5.6, shall be initiated at the start of every EFRAME which is also aligned to the Turbo code word.

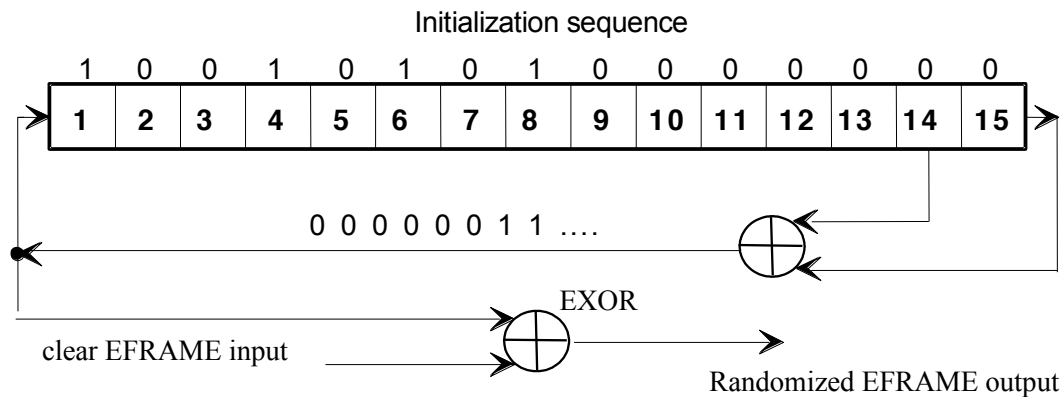

**Figure 5.6: Implementation of the PRBS encoder**

## 5.3 FEC encoding and channel interleaving

The Turbo Code as standardized by the 3GPP2 organization shall be used. Additional code rates with respect to the originally defined 3GPP2 code rates have been introduced to both allow finer granularity in terms of C/N adjustment and code combining between OFDM and TDM (see abbreviations).

The turbo encoder employs two systematic and recursive convolutional encoders connected in parallel, with an interleaver, the turbo interleaver, preceding the second recursive convolutional encoder. During encoding, an encoder output tail sequence is added. For any code rate, if the total number of bits encoded by the turbo encoder is  $L_{TC-input}$ , the turbo encoder generates  $(L_{TC-input} + 6)/CR$  encoded output symbols, where CR is the code rate. The two recursive convolutional codes are called the constituent codes of the turbo code. The outputs of the constituent encoders are punctured and repeated to achieve the  $(L_{TC-input} + 6)/CR$  output symbols.

$L_{TC-input}$  shall be set to 12 282 bits for content issued from the Stream Adaptation.

$L_{TC-input}$  shall be set to 1 146 bits for the signalling content (see clause 5.5).

### 5.3.1 Constituent codes of the turbo encoder and puncturing patterns

A common constituent code shall be used for all turbo codes. The transfer function for the constituent code shall be:

$$G(D) = \begin{bmatrix} 1 & \frac{n_0(D)}{d(D)} & \frac{n_1(D)}{d(D)} \end{bmatrix}$$

NOTE: With  $d(D) = 1 + D^2 + D^3$ ,  $n_0(D) = 1 + D + D^3$ , and  $n_1(D) = 1 + D + D^2 + D^3$ .

The turbo encoder shall generate an output symbol sequence that is identical to the one generated by the encoder shown in figure 5.7. Initially, the states of the constituent encoder registers in this figure are set to zero. Then, the constituent encoders are clocked with the switches in the positions noted.

Clocking the constituent encoders  $L_{TC-input}$  times with the switches in the up positions and puncturing the outputs as specified in table 5.2 generate the encoded data output symbols. Within a puncturing pattern, a '0' means that the symbol shall be deleted and a '1' means that a symbol shall be passed. The constituent encoder outputs for each bit period shall be output in the sequence X, Y<sub>0</sub>, Y<sub>1</sub>, X', Y'<sub>0</sub>, Y'<sub>1</sub> with the X output first. Symbol repetition is not used in generating the encoded data output symbols.

**Table 5.2: Puncturing patterns for the data bit periods**

Punct_Pat_ID	Code Rate	Pattern Name	Puncturing Pattern (X;Y <sub>0</sub> ;Y <sub>1</sub> ;X';Y' <sub>0</sub> ;Y' <sub>1</sub> ; X;Y <sub>0</sub> ;...)
0	1/5	Standard	1;1;1;0;1;1
1	2/9	Standard	1;0;1;0;1;1; 1;1;1;0;1;1; 1;1;1;0;0;1; 1;1;1;0;1;1
2	1/4	Standard	1;1;1;0;0;1; 1;1;0;0;1;1
3	2/7	Standard	1;0;1;0;0;1; 1;0;1;0;1;1; 1;0;1;0;0;1; 1;1;1;0;0;1
4	1/3	Standard	1;1;0;0;1;0
5	1/3	Complementary	1;0;1;0;0;1
6	2/5	Standard	1;0;0;0;0;0; 1;0;1;0;0;1; 0;0;1;0;0;1;
			1;0;1;0;0;1; 1;0;1;0;0;1; 0;0;1;0;0;1;
			1;0;1;0;0;1; 1;0;1;0;0;1; 0;0;1;0;0;1;
			1;0;1;0;0;1; 1;0;1;0;0;1; 0;0;1;0;0;1;
7	2/5	Complementary	1;1;0;0;1;0; 0;1;0;0;1;0; 1;1;0;0;1;0;
			1;1;0;0;1;0; 0;1;0;0;1;0; 1;0;0;0;0;0;
			1;1;0;0;1;0; 0;1;0;0;1;0; 1;1;0;0;1;0;
			1;1;0;0;1;0; 0;1;0;0;1;0; 1;1;0;0;1;0;
8	1/2	Standard	1;1;0;0;0;0; 1;0;0;0;1;0
9	1/2	Complementary	1;0;0;0;1;0; 1;1;0;0;0;0
10	2/3	Standard	1;0;0;0;0;0; 1;0;0;0;0;0; 1;0;0;0;0;0; 1;0;1;0;0;1
11	2/3	Complementary	1;0;0;0;0;0; 1;0;1;0;0;1; 1;0;0;0;0;0; 1;0;0;0;0;0

NOTE 1: For each rate, the puncturing table shall be read first from left to right and then from top to bottom.

NOTE 2: Depending on the puncturing scheme, the data bits encoding process does not always produce  $L_{TC-input} / CR$  bits. The total length is preserved by compensating the overall length with additional tail bits (e.g. for rates 2/5 and 2/3).

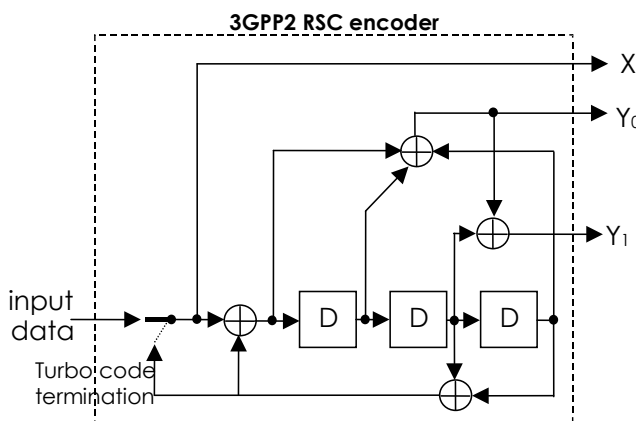
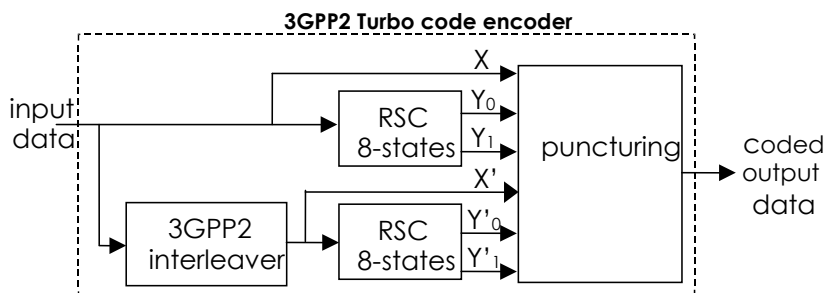

**Figure 5.7: Turbo encoder**

### 5.3.2 Turbo code termination

The turbo encoder shall generate tail output symbols following the encoded data output symbols. This tail output symbol sequence shall be identical to the one generated by the encoder shown in table 5.3. The tail output symbols are generated after the constituent encoders have been clocked  $L_{TC-input}$  times with the switches in the up position. The first tail output symbols are generated by clocking Constituent Encoder 1 three times with its switch in the down position while Constituent Encoder 2 is not clocked and puncturing and repeating the resulting constituent encoder output symbols. The last tail output symbols are generated by clocking Constituent Encoder 2 three times with its switch in the down position while Constituent Encoder 1 is not clocked and puncturing and repeating the resulting constituent encoder output symbols. The constituent encoder outputs for each bit period shall be output in the sequence  $X, Y_0, Y_1, X', Y'_0, Y'_1$  with the  $X$  output first.

The tail output symbol puncturing and symbol repetition shall be as specified in table 5.3. Within a puncturing pattern, a '0' means that the symbol shall be deleted and a '1' means that a symbol shall be passed. A 2 or a 3 means that two or three copies of the symbol shall be passed.

- For the rate 1/5 turbo code (Punct\_Pat\_ID=0), the tail output symbols for each of the first three tail bit periods shall be  $XXX Y_0 Y_1$ , and the tail output symbols for each of the last three tail bit periods shall be  $X'X'Y'_0 Y'_1$ .
- For the rate 2/9 turbo code (Punct\_Pat\_ID=1), the tail output symbols for the first and the second output period shall be  $XXX Y_0 Y_1$ , for the third output period  $XX Y_0 Y_1$ , for the fourth and fifth output period  $X'X'Y'_0 Y'_1$ , and for the sixth (last) output period  $X'X'X'Y'_0 Y'_1$ .
- For the rate 1/4 turbo code (Punct\_Pat\_ID=2), the tail output symbols for each of the first three tail bit periods shall be  $XX Y_0 Y_1$ , and the tail output symbols for each of the last three tail bit periods shall be  $X'X' Y'_0 Y'_1$ .
- All other code rates shall be processed similar to the given examples above with the exact puncturing patterns to be derived from table 5.3.

Table 5.3: Puncturing and symbol repetition patterns for the tail bit periods

Punct_Pat_ID	Code Rate	Pattern Name	Tail Puncturing Pattern
			(X;Y <sub>0</sub> ;Y <sub>1</sub> ;X';Y' <sub>0</sub> ;Y' <sub>1</sub> ; X;Y <sub>0</sub> ;Y <sub>1</sub> ;X';Y' <sub>0</sub> ;Y' <sub>1</sub> ; X;Y <sub>0</sub> ;Y <sub>1</sub> ;X';Y' <sub>0</sub> ;Y' <sub>1</sub> ; X;Y <sub>0</sub> ;Y <sub>1</sub> ;X';Y' <sub>0</sub> ;Y' <sub>1</sub> ; X;Y <sub>0</sub> ;Y <sub>1</sub> ;X';Y' <sub>0</sub> ;Y' <sub>1</sub> ; X;Y <sub>0</sub> ;Y <sub>1</sub> ;X';Y' <sub>0</sub> ;Y' <sub>1</sub> )
0	1/5	Standard	3;1;1;0;0;0; 3;1;1;0;0;0; 3;1;1;0;0;0; 0;0;0;3;1;1; 0;0;0;3;1;1; 0;0;0;3;1;1
1	2/9	Standard	3;1;1;0;0;0; 3;1;1;0;0;0; 2;1;1;0;0;0; 0;0;0;2;1;1; 0;0;0;2;1;1; 0;0;0;3;1;1
2	1/4	Standard	2;1;1;0;0;0; 2;1;1;0;0;0; 2;1;1;0;0;0; 0;0;0;2;1;1; 0;0;0;2;1;1; 0;0;0;2;1;1
3	2/7	Standard	1;1;1;0;0;0; 2;1;1;0;0;0; 2;1;1;0;0;0; 0;0;0;2;1;1; 0;0;0;1;1;1; 0;0;0;1;1;1
4	1/3	Standard	2;1;0;0;0;0; 2;1;0;0;0;0; 2;1;0;0;0;0; 0;0;0;2;1;0; 0;0;0;2;1;0; 0;0;0;2;1;0
5	1/3	Complementary	2;0;1;0;0;0; 2;0;1;0;0;0; 2;0;1;0;0;0; 0;0;0;2;0;1; 0;0;0;2;0;1; 0;0;0;2;0;1
6	2/5	Standard	1;1;1;0;0;0; 1;1;1;0;0;0; 1;0;1;0;0;0; 0;0;0;1;1;1; 0;0;0;1;1;1; 0;0;0;1;0;1
7	2/5	Complementary	1;1;1;0;0;0; 1;1;0;0;0;0; 1;1;1;0;0;0; 0;0;0;1;1;1; 0;0;0;1;1;0; 0;0;0;1;1;1
8	1/2	Standard	1;1;0;0;0;0; 1;1;0;0;0;0; 1;1;0;0;0;0; 0;0;0;1;1;0; 0;0;0;1;1;0; 0;0;0;1;1;0
9	1/2	Complementary	1;0;1;0;0;0; 1;0;1;0;0;0; 1;0;1;0;0;0; 0;0;0;1;0;1; 0;0;0;1;0;1; 0;0;0;1;0;1
10	2/3	Standard	1;0;0;0;0;0; 1;0;1;0;0;0; 1;0;1;0;0;0; 0;0;0;1;0;0; 0;0;0;1;0;1; 0;0;0;1;0;1
11	2/3	Complementary	1;0;1;0;0;0; 1;0;0;0;0;0; 1;0;0;0;0;0; 0;0;0;1;0;1; 0;0;0;1;0;0; 0;0;0;1;0;0

NOTE 1: For each rate, the puncturing table shall be read first from left to right and then from top to bottom.

NOTE 2: It should be noted that the tail size is not always 6 / CR, e.g. for rates 2/5 and 2/3. See table 5.2.

### 5.3.3 Turbo interleavers

The turbo interleaver shall be functionally equivalent to an approach where the entire sequence of turbo interleaver input bits are written sequentially into an array at a sequence of addresses, and then the entire sequence is read out from a sequence of addresses that are defined by the procedure described below. Let the sequence of input addresses be from 0 to  $L_{TC-input} - 1$ , where  $L_{TC-input}$  is the total number of information bits, frame quality indicator bits, and reserved bits in the turbo interleaver. Then, the sequence of interleaver output addresses shall be equivalent to those generated by the procedure illustrated in figure 5.8 and described below:

- 1) Determine the turbo interleaver parameter,  $n$ , where  $n$  is the smallest integer such that  $L_{TC-input} \leq 2^{n+5}$ . Table 5.4 gives this parameter for the numbers of bits per frame that are available without flexible data rates.
- 2) Initialize an  $(n + 5)$ -bit counter to 0.
- 3) Extract the  $n$  most significant bits (MSBs) from the counter and add one to form a new value. Then, discard all except the  $n$  least significant bits (LSBs) of this value.
- 4) Obtain the  $n$ -bit output of the table lookup defined in table 5.5 with read address equal to the five LSBs of the counter. Note that this table depends on the value of  $n$ .
- 5) Multiply the values obtained in Steps 3 and 4, and discard all except the  $n$  LSBs.
- 6) Bit-reverse the five LSBs of the counter.
- 7) Form a tentative output address that has its MSBs equal to the value obtained in Step 6 and its LSBs equal to the value obtained in Step 5.
- 8) Accept the tentative output address as an output address if it is less than  $L_{TC-input}$ ; otherwise, discard it.

- 9) Increment the counter and repeat Steps 3 through 8 until all  $L_{TC-input}$  interleaver output addresses are obtained.

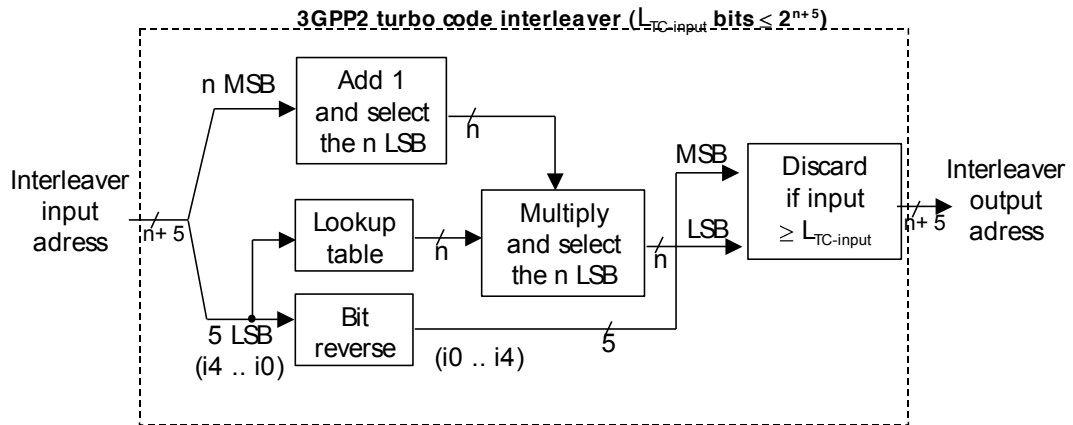

**Figure 5.8: Turbo interleaver output address calculation procedure**

**Table 5.4: Turbo interleaver parameters**

Turbo interleaver block size $L_{TC-input}$	Turbo interleaver parameter $n$
1 146	6
12 282	9

**Table 5.5: Turbo interleaver look-up table definition**

Table index	n = 6	n = 9
0	3	13
1	27	335
2	15	87
3	13	15
4	29	15
5	5	1
6	1	333
7	31	11
8	3	13
9	9	1
10	15	121
11	31	155
12	17	1
13	5	175
14	39	421
15	1	5
16	19	509
17	27	215
18	15	47
19	13	425
20	45	295
21	5	229
22	33	427
23	15	83
24	13	409
25	9	387
26	15	193
27	31	57
28	17	501
29	5	313
30	15	489
31	33	391

## 5.4 Channel interleaver and rate adaptation

### 5.4.1 Overview

Interleavers are introduced to enhance the resistance of the waveform to short-term fading and medium-term shadowing/blockage impairments in terrestrial and satellite channels. The interleaver diversity is largely provided by a common channel time interleaver. An additional symbol interleaver specific for the OFDM is described in clause 5.7.2.

The channel time interleaver is composed of two cascaded elementary interleavers, a block bit-wise interleaver working on individual coded words at the output of the encoder, and a convolutional time interleaver working on Interleaving Units (IUs) of 126 bits. A rate adaptation is inserted at the output of the bitwise interleaver in order to match the coded words to an integer number of IUs.

The bit and time interleaving processes do not depend on modulation scheme, since they are working on interleaving units. However the resulting duration of the interleaving depends on the modulation.

### 5.4.2 Bit-wise interleaving and rate adaptation

The output of the Turbo encoder shall be bit interleaved using a block interleaver. The values for block interleaving are given in table 5.6 for the turbo input block size of 1 146 bits (signalling field) and table 5.7 for the turbo input block size of 12 282 bits (payload).

**Table 5.6: Bit wise interleaver function for turbo input block size of 1 146 bits**

Code rate	$N_{TCB}$	H(w) function
1/5	5 760	$H(w) = (73 \times w) \bmod 5\,760$

**Table 5.7: Bit wise interleaver function for turbo block size of 12 282 bits**

Code rate	$N_{TCB}$	H(w) function
1/5	61 440	$H(w) = (247 \times w) \bmod 61\,440$
2/9	55 296	$H(w) = (245 \times w) \bmod 55\,296$
1/4	49 152	$H(w) = (221 \times w) \bmod 49\,152$
2/7	43 008	$H(w) = (197 \times w) \bmod 43\,008$
1/3	36 864	$H(w) = (185 \times w) \bmod 36\,864$
2/5	30 720	$H(w) = (167 \times w) \bmod 30\,720$
1/2	24 576	$H(w) = (157 \times w) \bmod 24\,576$
2/3	18 432	$H(w) = (125 \times w) \bmod 18\,432$

The bit vector at the FEC coding output is defined by:  $A = (a_0, a_1, a_2, \dots, a_{N_{TCB}-1})$ , where  $N_{TCB}$  is the number of bits of the FEC coded block.

The interleaved output vector is named  $B = (b_0, b_1, b_2, \dots, b_{N_{TCB}-1})$ .

B is defined by:  $b_w = a_{H(w)}$  with w running from 0 to  $N_{TCB}-1$ .

For mapping optimization on the DVB-SH frame purpose, the interleaved FEC blocks *for the payload* are punctured after bit interleaver. Every sequence of 128 bits is punctured, such that the first 126 bits are used, whereas the last 2 bits are discarded. In total,  $N_{BIL}$  output bits (see table 5.8) of the bit wise interleaver output B are used, whereas  $N_{PB} = N_{TCB} - N_{BIL}$  output bits of the bit wise interleaver output B are discarded.

The output X of the bit-wise interleaver after puncturing the last bits is defined as follows:

$$X = (x_0, x_1, x_2, \dots, x_{N_{BIL}-1}) = (b_0, b_1, b_2, \dots, b_{125}, b_{128}, b_{129}, \dots, b_{253}, b_{256}, b_{257}, \dots, b_{N_{TCB}-3})$$

This puncturing is only introduced for the turbo input block length of 12 282 bits, but not for the turbo input block length of 1 146 bits.

Table 5.8 gives the size of the interleaved and punctured blocks before and after the bit-wise interleaver for the turbo input block length of 12 282 bits.

**Table 5.8: Output FEC block sizes for the turbo input block size of 12 282 bits**

Code rate	Turbo Block size		Punctured Bits ( $N_{PB}$ )
	At coder output ( $N_{TCB}$ )	After block interleaver and puncturing ( $N_{BIL}$ )	
	(bits)	(bits)	(bits)
1/5	61 440	60 480	960
2/9	55 296	54 432	864
1/4	49 152	48 384	768
2/7	43 008	42 336	672
1/3	36 864	36 288	576
2/5	30 720	30 240	480
1/2	24 576	24 192	384
2/3	18 432	18 144	288

### 5.4.3 Time interleaver

The purpose of the time interleaver is to interleave coded words bits over time using a convolutional interleaver. The conceptual view of the interleaver is presented in figure 5.9. Time interleaver takes as input a sequence of non-interleaved Interleaving Units (IU) of 126 bits cells which come from the rate adaptation process that punctures the output of the bit interleaver, plus the padding generated in the case of the OFDM mode. The convolutional interleaver is defined by:

- The number of branches shall always equals 48.
- Branches are cyclically connected to the input stream by the input switch (the input and output switches shall be synchronized).
- Each branch  $j$  shall be a First-In First-Out (FIFO) shift register, with depth  $L(j)$  cells. The value of each branch is computed according to the values signalled by the TPS or the header signalling field (SF), depending on whether OFDM or TDM is used.
- The cells of the FIFO shall contain a 126 bit symbol (IU).

For each cycle of the interleaver, 48 non-interleaved IUs are read sequentially (starting on a coded word) and fed into the branches. The output of the interleaver is the 48 interleaved IU. Output is read synchronously with the input.

Figure 5.9 depicts the functionality of any convolutional interleaver and illustrates the principle.

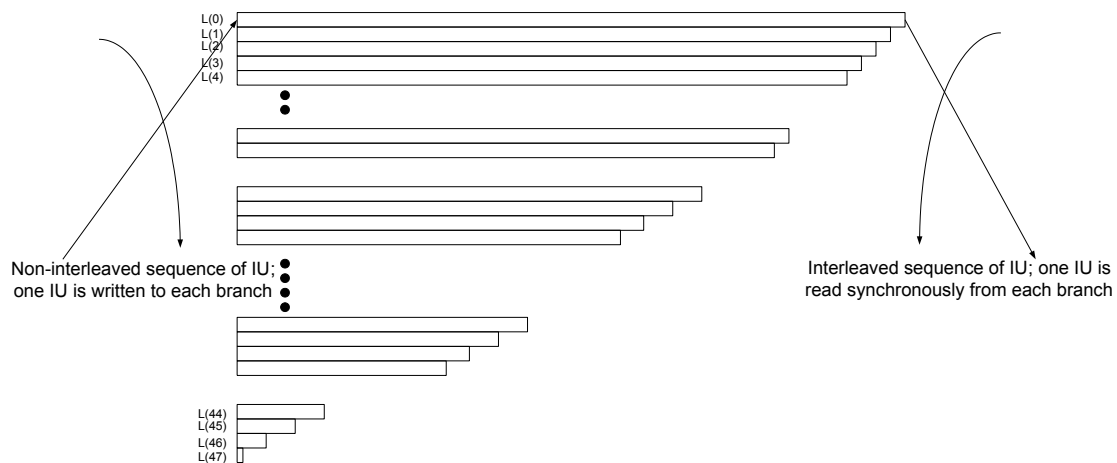
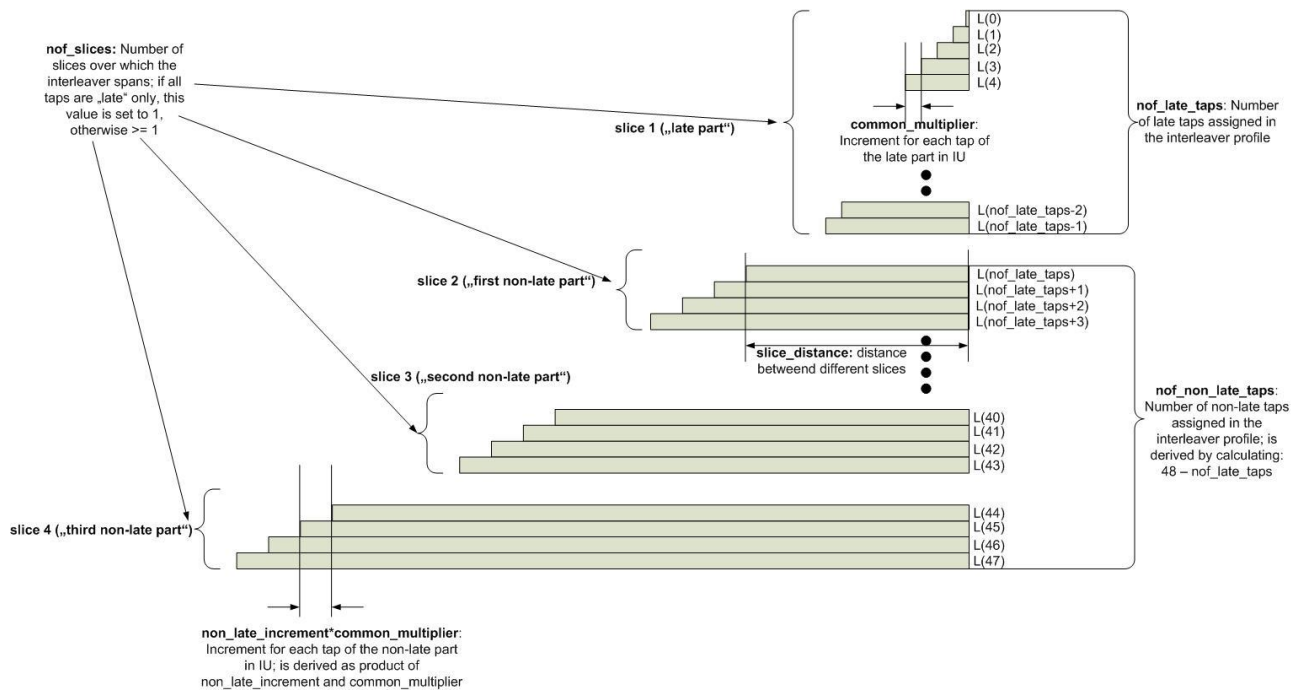

**Figure 5.9: Conceptual diagram of the time interleaver**

The depth of the shift registers  $L(0)$  to  $L(47)$  of each branch has a settable delay that is:

- either configured through TPS (OFDM mode).
- and/or configured through header signalling field SF (TDM mode).

Within the present document, the definition of the branch delays of the interleaver is described from the *receivers'* point of view. In particular, the parameters contained in the TPS or the header signalling field SF shall use this definition. To differentiate from the transmitter point of view, branches are referred to as a taps in the following. The value for  $L(0)$  is always set to 0.



**Figure 5.10: Interleaver branch delay description from receivers' point of view**

## 5.5 Frame structure

### 5.5.1 Interface with FEC encoding

Turbo code word framing is fully synchronized with SH frame (start of a SH frame is start of an encoded word).

### 5.5.2 SH Frame structure

#### 5.5.2.1 Overview

The bitwise interleaver followed by the rate adaptation produce Interleaving Units (IUs) of 126 bits which are fed into the time interleaver but those IU are coming from:

- The DATA only part for TDM mode.
- The DATA and PADDING parts for OFDM mode.

Those bit streams are assembled to produce SH frames.

An overview to the processing steps is given in figure 5.11 for mode OFDM and figure 5.12 for mode TDM.

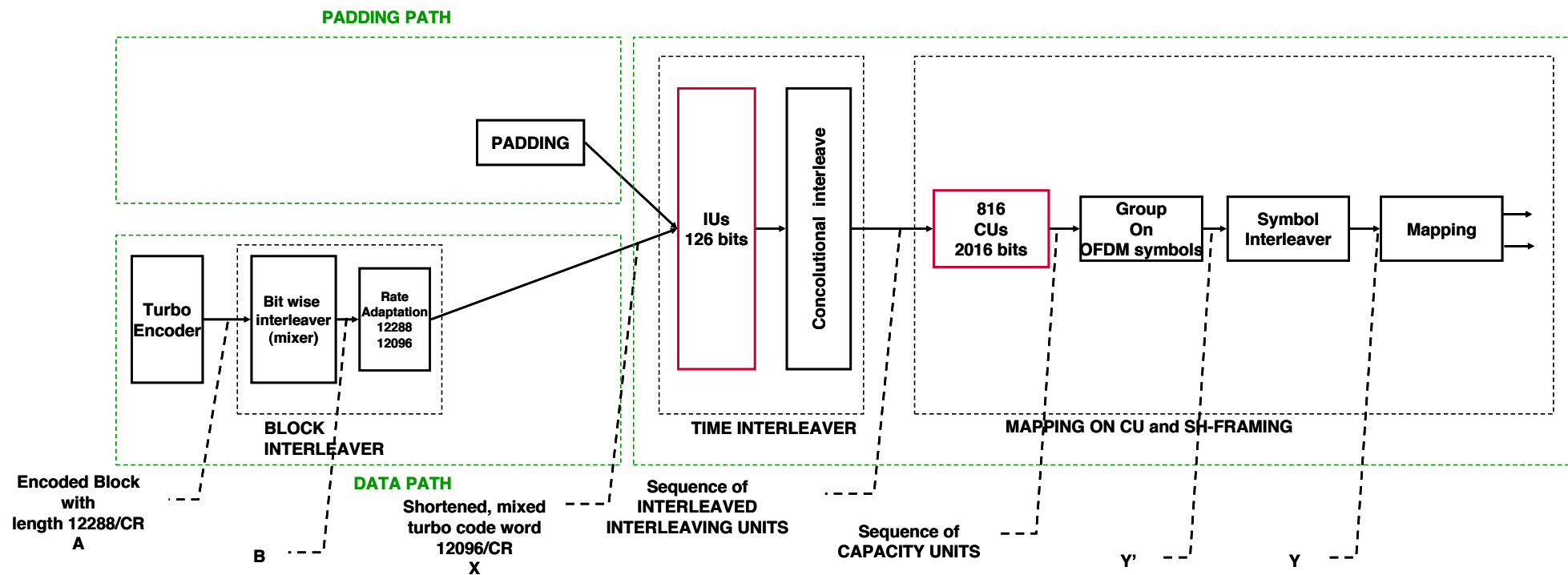

Figure 5.11: Overview of the interleaving processing steps for OFDM modulation

For TDM the processing steps are nearly identical although simpler since symbol interleaving is not required for TDM.

The major difference in the processing is that TDM frames start with a header (as described in clause 5.5.2.2) which shall not be interleaved with the data and padding parts.

Different time interleaver can be used for TDM and for OFDM but if same FEC and interleaver parameters are used for TDM as for OFDM, the vector  $Y'$  shall be identical.

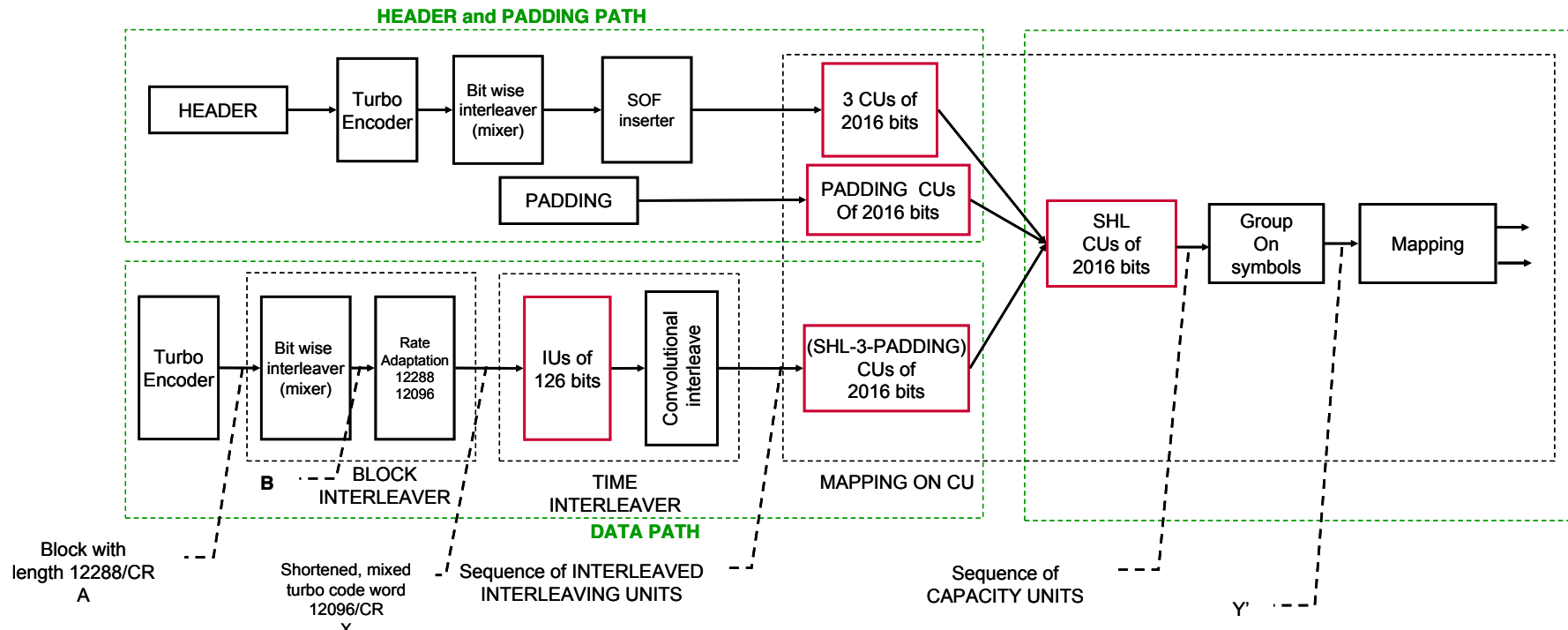

Figure 5.12: Overview of the interleaving processing steps for TDM modulation

### 5.5.2.2 Elementary parts description

The SH frame is composed of an integer number of Capacity Units (CU) of 2 016 bits each. The SH frame can be composed of 3 successive parts: HEADER, DATA and PADDING.

#### HEADER PART:

The HEADER part is composed of:

- SOF: Start Of Frame Preamble of length 288 bits.
- SF: Signalling Field of length 5 760 bits.

The SOF value is described hereafter:

```
F3484536 B855DF1B 6FD32468 F368BC5A 6CD02627 074CB0A4 11979705 08F31EDD ACCF9E4F
```

First bits to be transmitted first (Big endians).

The Signalling Field is described hereafter:

- The code rate 1/5 is used for the signalling field. The resulting size of the payload is 1146 bits. The signalling field contains all parameters necessary for coding and interleaving. It may be extended in further revisions of the present document.

After the parameter clause, a CRC-16 is included. The rest of the signalling field is padded with zeros.

**Table 5.9: TDM signalling field description**

Parameters for the DVB-SH frame with signalling field					
Start bit index	Parameter	Description	Wordsize (bits)	Format	Comment
0	Signalling_Version	Version number of the DVB-SH signalling format	8	U8	Fixed to 0 other values are RFU If values are $\neq 0$ the receiver shall ignore the signalling field.
8	RFU	RFU	8	U8	RFU bits
16	Frame_Width_CUs	DVB-SH frame width in Cus	12	U12	CUs are used as the unit in order to allow receivers to know the width of the DVB-SH frame.
28	Punct_Pad_ID	ID number of the Turbo code puncturing pattern	4	U4	See table 5.2.
32	Common_multiplier	Tap length common multiplier	6	U6	Values from [1...63], is by default the "late" part step; 0 is not allowed.
38	Nof_late_taps	Number of taps in the late category	6	U6	Values from [0...48], whereas "0" signals no late part available, and "48" signals only late part available.
44	Nof_slices	Number of slices over which the data is distributed	6	U6	Values from [1...63], if only late part is used, this value must be set to 1.
50	Slice_distance	Distance between two slices	8	U8	Values from [0...255]; must be multiplied with the SH frame capacity in IU and divided by 48 to get increment in IU. Value set to 0 if interleaver applies only to 1 slice.
58	Non_late_increment	Increment between taps inside the non-late slice(s)	6	U6	Values from [0...63]; must be multiplied with common_multiplier to get increment in IU. Value set to 0 if interleaver applies only to 1 slice.
64	RFU	RFU	32	U32	RFU bits.
96	CRC_16	CRC-16 over the first 96 bits	16	U16	Polynomial as defined in clause 5.1.1.
112	RFU	RFU	1 034	U1	Remaining bits are RFU bits.
<b>Total length of Signalling field</b>			<b>1 146</b>		

The signalling field is turbo encoded, using the same structure of the turbo code as described in clause 5.3.

It uses the same puncturing patterns for the payload part and the tail part as the Punct\_Pat\_ID=0 (code rate 1/5). The code word length for the signalling field is 1 146 bits.

## DATA PART

The DATA part is made of an integer number of punctured code words generated after the bitwise interleaver as described in 5.4.2, this number being a function of the chosen code rate and the punctured code word length. The resulting punctured coded word length is an integer number of CUs for all coding rates.

## PADDING PART

The PADDING part (if existing) is used to complete the SH frame, such that it always contains a fixed number of CU, independent of the chosen code rate.

The PADDING part length depends on the chosen FEC code rate and is composed by an integer number of CUs.

Padding sequence is generated using the same PRBS encoder as the one used in EScrambler, with the input constantly set to 0. Loading of the sequence (100101010000000) into the PRBS register, as indicated in figure 5.13, shall be initiated for every SH frame.

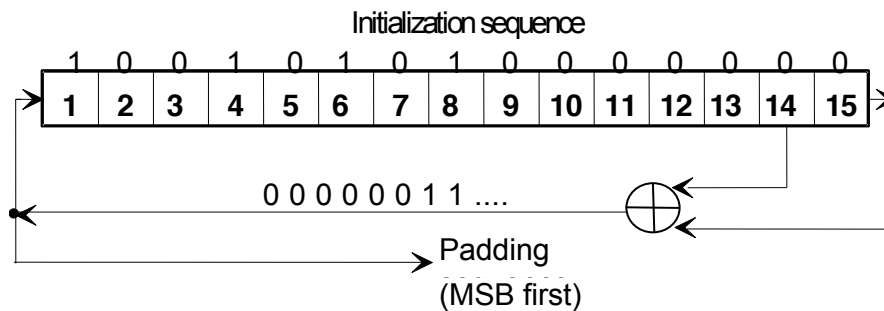

**Figure 5.13: Implementation of the padding part generator for SH frame completion**

The length of the SH frame *in time* is derived from the DVB-SH parameters for OFDM transmission, and the SH frame length for TDM has been aligned to these values.

This alignment *in time* is depicted in figure 5.14. The values for SHL<sub>1</sub>, SHL<sub>2</sub> and SHL<sub>3</sub> can be derived from table 5.12.

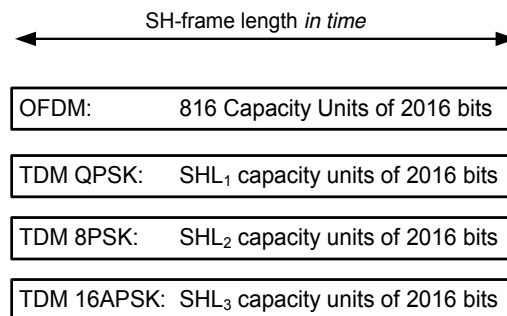

**Figure 5.14: SH frame length in capacity units for TDM and OFDM**

For providing synchronization between all transmitters (OFDM and, TDM if any) a SH-IP packet is introduced. See description in annex A.

### 5.5.2.3 OFDM mode

The OFDM SH frame is made of 816 CUs, whatever the modulation choice. It is also not dependent on guard interval or bandwidth selection.

The length of the SH frame in OFDM super frames is a function of the selected modulation and the FFT mode, as given in table 5.10.

Table 5.10: SH frame mapping to OFDM Super-frames

Mapping	FFT length	OFDM frames per SH frame	OFDM Super frames per SH frames
QPSK and 16-QAM hierarchical	1K	16	4
	2K	8	2
	4K	4	1
	8K	2	1/2 (=2 SH frames per OFDM super frame)
16-QAM	1K	8	2
	2K	4	1
	4K	2	1/2 (= 2 SH frames per OFDM super frame)
	8K	1	1/4 (= 4 SH frames per OFDM super frame)

The OFDM SH frame does not include any HEADER part.

The OFDM SH frame has:

- A DATA part of variable size, depending on the selected code rate, up to the full capacity of the SH frame of 816 CUs.
- A PADDING part of variable size equal to 816-DATA size.

Table 5.11 describes the length of the DATA and PADDING parts.

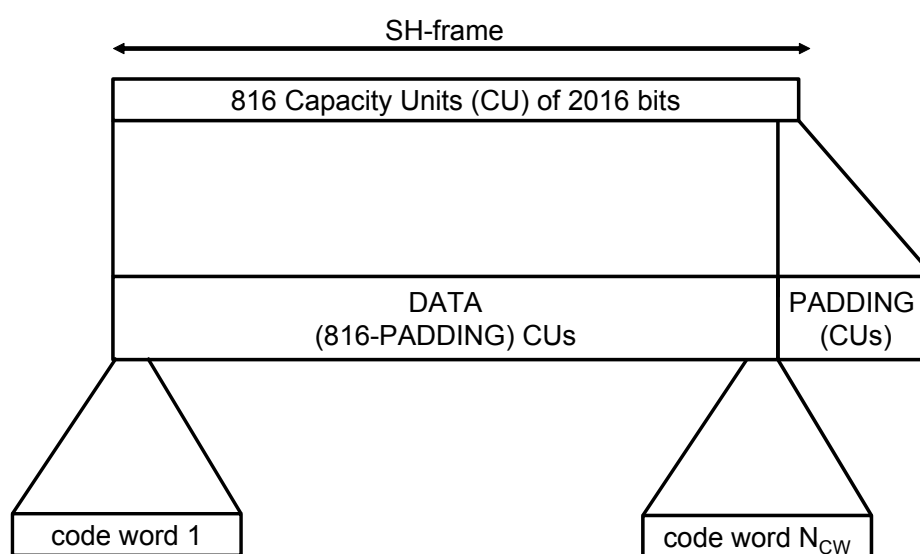

Figure 5.15: SH frame structure for OFDM

Table 5.11: DATA and PADDING length for OFDM SH frame structure

Code rate	1/5	2/9	1/4	2/7	1/3	2/5	1/2	2/3
DATA (CUs)	810	810	816	798	810	810	816	810
PADDING (CUs)	6	6	0	18	6	6	0	6
SH frame (CUs)	816	816	816	816	816	816	816	816
Punctured Code words per SH frame ( $N_{CW}$ )	27	30	34	38	45	54	68	90

#### 5.5.2.4 TDM mode

The number of CU per TDM SH frame is dependent on the selected TDM modulation format, the TDM square-root raised-cosine roll-off factor and the OFDM guard interval length. The appropriate values are given in table 5.12.

The TDM SH frame includes:

- A HEADER part whose size is fixed to 3 CUs long as specified in clause 5.5.2.2, with a signalling field as defined in table 5.9.
- A DATA part of variable size, depending on the selected code rate, up to the full capacity of the TDM SH frame.
- A PADDING part of variable size, depending on the selected code rate.

Figure 5.16 displays the structure of the TDM SH frame.

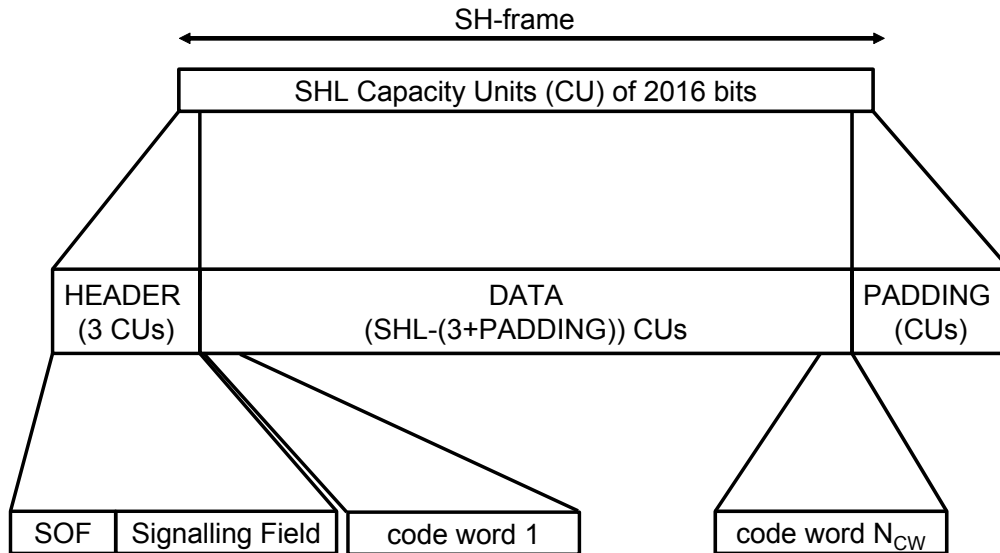

Figure 5.16: SH frame structure for TDM

### 5.5.3 Interface with modulation

The interleaver units (IU) of size 126 bits each are again grouped to capacity units (CU) of size 2 016 bits each.

The sequence of capacity units at the output of the interleaver is considered as continuous bit stream and units of CUs are read to fill OFDM and/or TDM symbols.

## 5.6 Single carrier (TDM)

### 5.6.1 Interface to SH frame

Combined operation of Single Carrier (coming from the satellite) and Multi Carrier (coming from terrestrial network) has an impact on the frame parameters: to simplify the diversity reception of both signals in hybrid TDM/OFDM environment, the framing duration for the TDM waveform is made identical to the framing duration for the OFDM waveform.

Since each may use different bandwidth and FEC coding rates, this leads to different symbol and bit rates and hence capacity units.

The interface to the time interleaver is the SH frame composed of the number of capacity units listed in table 5.12 as a function of the TDM and OFDM physical layer parameters, assuming that TDM and OFDM have the same channel bandwidth (only the 5 MHz case is presented in table 5.12).

Table 5.12: TDM SH FRAME transport capability in Capacity Units

OFDM Guard Interval	TDM Rolloff	OFDM: QPSK TDM: QPSK	OFDM: QPSK TDM: 8PSK	OFDM: QPSK TDM: 16APSK	OFDM: 16QAM TDM: QPSK	OFDM: 16QAM TDM: 8PSK	OFDM: 16QAM TDM: 16APSK
1/4	0,15	952	1 428	1 904	476	714	952
1/4	0,25	896	1 344	1 792	448	672	896
1/4	0,35	812	1 218	1 624	406	609	812
1/8	0,15	868	1 302	1 736	434	651	868
1/8	0,25	784	1 176	1 568	392	588	784
1/8	0,35	728	1 092	1 456	364	546	728
1/16	0,15	812	1 218	1 624	406	609	812
1/16	0,25	756	1 134	1 512	378	567	756
1/16	0,35	700	1 050	1 400	350	525	700
1/32	0,15	784	1 176	1 568	392	588	784
1/32	0,25	728	1 092	1 456	364	546	728
1/32	0,35	672	1 008	1 344	336	504	672

The signalling information is transmitted once each SH frame period. No additional TDM signalling is introduced. At the beginning of each SH frame, three capacity units as specified in clause 5.5.2.2 carry all relevant signalling information. The signalling field is mapped like the payload data of the SH frame.

## 5.6.2 Bit mapping into constellation

QPSK, 8PSK and 16APSK constellations and the associated mapping as defined by DVB-S2 in reference [2], clause 5.4, shall be used.

Each  $Y'$  vector as described in clause 5.5.2.1 is organized into groups of  $\eta_{\text{MOD}}$  bits ( $\eta_{\text{MOD}}$ , equal to 2 for QPSK, 3 for 8PSK, and 4 for 16APSK) as depicted in figures 5.17 to 5.19. The MSB of each group of  $\eta_{\text{MOD}}$  bits is mapped into the MSB of the constellation. Each group of  $\eta_{\text{MOD}}$  bits generates one complex value in the format (I,Q) with I being the in-phase component and Q the quadrature component. The output sequence has the length of  $Y'/\eta_{\text{MOD}}$  complex values.

### 5.6.2.1 Bit mapping into QPSK constellation

For QPSK, the System shall employ conventional Gray-coded QPSK modulation with absolute mapping (no differential coding). Bit mapping into the QPSK constellation shall follow figure 5.17. The normalized average energy per symbol shall be equal to  $\rho^2 = 1$ .

Two bits are mapped to a QPSK symbol.

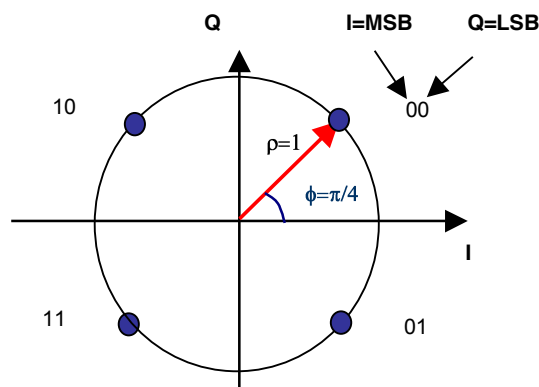

Figure 5.17: Bit mapping into QPSK constellation

### 5.6.2.2 Bit mapping into 8PSK constellation

For 8PSK, the System shall employ conventional Gray-coded 8PSK modulation with absolute mapping (no differential coding). Bit mapping into the 8PSK constellation shall follow figure 5.18. The normalized average energy per symbol shall be equal to  $\rho^2 = 1$ .

Three bits are mapped to an 8PSK symbol.

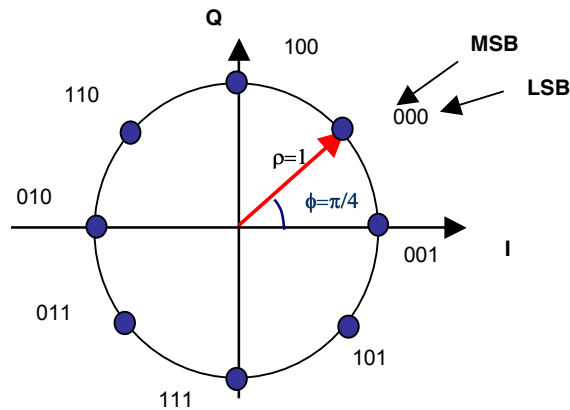

Figure 5.18: Bit mapping into 8PSK constellation

### 5.6.2.3 Bit mapping into 16APSK constellation

The 16APSK modulation constellation (figure 5.19) shall be composed of two concentric rings of uniformly spaced 4 and 12PSK points, respectively in the inner ring of radius  $R_1$  and outer ring of radius  $R_2$ .

The ratio of the outer circle radius to the inner circle radius ( $\gamma = R_2/R_1$ ) shall be equal to 3.

$R_1$  shall be set to  $1/\sqrt{7}$ ,  $R_2$  shall be set to  $3/\sqrt{7}$  in order to have the average signal energy equal to 1.

Four bits are mapped to a 16APSK symbol.

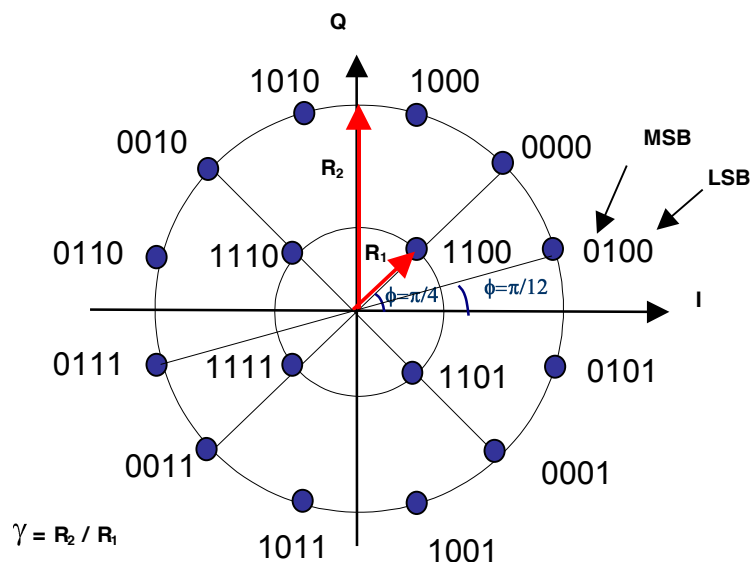

Figure 5.19: Bit mapping into 16APSK signal constellation

### 5.6.3 TDM symbol rate selection

As OFDM definition relies on the DVB-T standard, TDM Frame time duration is constrained by the OFDM frame duration which value varies with bandwidth, guard Interval setting and modulation order. The specified TDM framing is defined such as to cope with these frame time duration variation.

The symbol rates for TDM are defined in table 5.13. The selection of the TDM symbol rates takes into account the OFDM parameters.

**Table 5.13: TDM symbol rates for all channelizations and as a function of the OFDM parameter settings (sampling frequency and guard interval) and of the TDM roll-off factor**

Signal Bandwidth in MHz	OFDM Sampling frequency in MHz	OFDM Guard Interval	TDM Symbol rate in MHz	TDM Roll-Off Factor	TDM Symbol rate in MHz	TDM Roll-Off Factor	TDM Symbol rate in MHz	TDM Roll-Off Factor
8,00	64/7	1/4	34/5	0,15	32/5	0,25	29/5	0,35
8,00	64/7	1/8	62/9	0,15	56/9	0,25	52/9	0,35
8,00	64/7	1/16	116/17	0,15	108/17	0,25	100/17	0,35
8,00	64/7	1/32	224/33	0,15	208/33	0,25	64/11	0,35
7,00	8/1	1/4	119/20	0,15	28/5	0,25	203/40	0,35
7,00	8/1	1/8	217/36	0,15	49/9	0,25	91/18	0,35
7,00	8/1	1/16	203/34	0,15	189/34	0,25	175/34	0,35
7,00	8/1	1/32	196/33	0,15	182/33	0,25	56/11	0,35
6,00	48/7	1/4	51/10	0,15	24/5	0,25	87/20	0,35
6,00	48/7	1/8	31/6	0,15	14/3	0,25	13/3	0,35
6,00	48/7	1/16	87/17	0,15	81/17	0,25	75/17	0,35
6,00	48/7	1/32	56/11	0,15	52/11	0,25	48/11	0,35
5,00	40/7	1/4	17/4	0,15	4/1	0,25	29/8	0,35
5,00	40/7	1/8	155/36	0,15	35/9	0,25	65/18	0,35
5,00	40/7	1/16	145/34	0,15	135/34	0,25	125/34	0,35
5,00	40/7	1/32	140/33	0,15	130/33	0,25	40/11	0,35
1,70	64/35	1/4	34/25	0,15	32/25	0,25	29/25	0,35
1,70	64/35	1/8	62/45	0,15	56/45	0,25	52/45	0,35
1,70	64/35	1/16	116/85	0,15	108/85	0,25	20/17	0,35
1,70	64/35	1/32	224/165	0,15	208/165	0,25	64/55	0,35

### 5.6.4 TDM framing

#### 5.6.4.1 PL Slot definition

The SH frame to be transmitted in TDM mode consists of a number of Physical layer Slots (PL SLOTS) of length  $L_{TDF}=2176$  symbols, each of them comprising of 2, 3 or 4 capacity units (CU) of 2 016 bits as defined in clause 5.5.2.4.

The capacity units are directly mapped on PL SLOTS, dependent on the modulation format as described in table 5.14.

**Table 5.14: TDM framing, number of CU per PL slot**

Modulation	CU per PL SLOT
QPSK	2
8PSK	3
16APSK	4

As discussed in clause 5.6.1, the number of capacity units per SH frame depends on the selection of OFDM modulation, guard interval and roll-off selection. A few examples are given here (figures 5.20, to 5.22) to illustrate the relationship between CU and PL SLOTS.

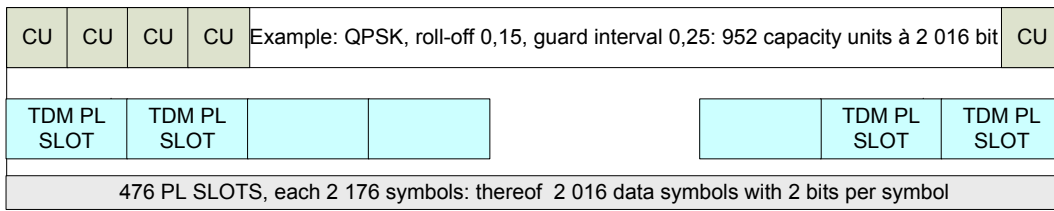

Figure 5.20: Example of TDM frame for QPSK

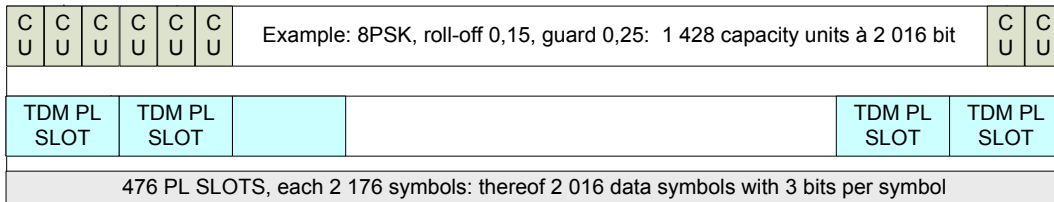

Figure 5.21: Example of TDM frame for 8PSK

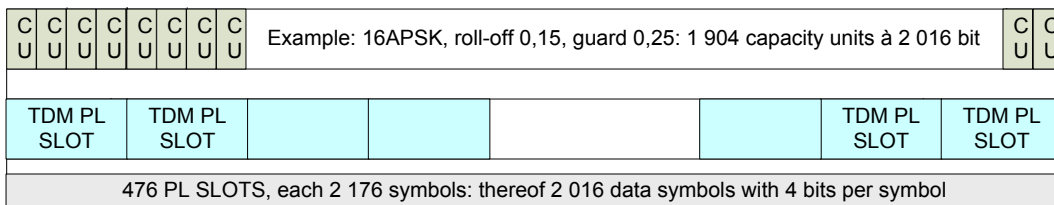

Figure 5.22: Example of TDM frame for 16APSK

5.6.4.2 Pilot insertion

In each PL SLOT there are two PILOT FIELDS of equal duration  $L_{PF} = 80$  symbols. Each pilot symbol shall be an un-modulated symbol, identified by:

$$I = \frac{1}{\sqrt{2}} \text{ and } Q = \frac{1}{\sqrt{2}}$$

A PILOT FIELD shall be inserted before each SUB-SLOT of length  $L_{SS} = 1\ 008$  symbols. The pilot organization in the PL SLOT is described in figure 5.23.

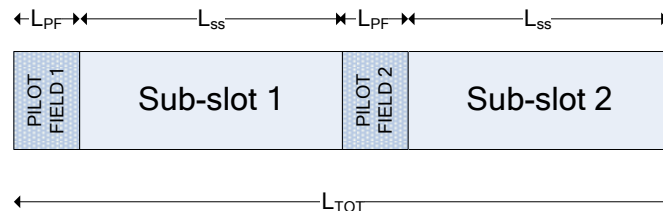

Figure 5.23: Slot pilot insertion

### 5.6.4.3 Physical layer scrambling

Prior to modulation, each PL SLOT including the PILOT FIELDS, shall be randomized for energy dispersal by multiplying for each PL SLOT of length  $L_{TOT}$  the I and Q modulated baseband signal symbol samples by a unique complex randomization sequence:

$$C(i) = C_I(i) + jC_Q(i), \quad i=1,2,\dots,L_{TOT}$$

So that:

$$I_{SCR}(i) = I(i)C_I(i) - Q(i)C_Q(i), \quad Q_{SCR}(i) = I(i)C_Q(i) + Q(i)C_I(i), \quad i=1,2,\dots,L_{TOT}.$$

The randomization sequence shall be reinitialized at the beginning of each PL SLOT, i.e. terminated after  $L_{TOT}$  symbols (see figure 5.24).

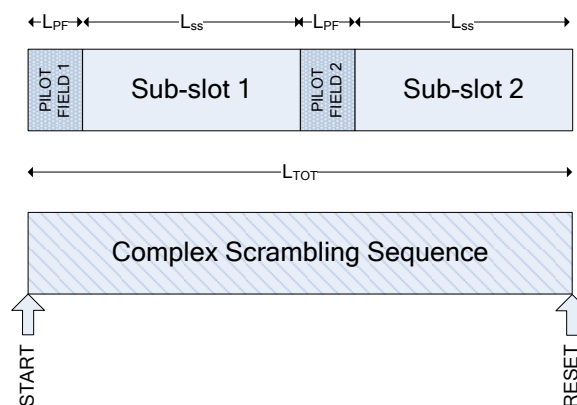

**Figure 5.24: PL Scrambling**

The scrambling code sequence shall be constructed by combining two real m-sequences (generated by means of two generator polynomials of degree 18) into a complex sequence. The resulting sequences thus constitute segments of a set of Gold sequences.

Only one complex sequence  $C_I(i) + jC_Q(i)$  is required for DVB-SH.

Let  $x$  and  $y$  be the two real sequences respectively. The  $x$  sequence is constructed using the primitive (over  $GF(2)$ ) polynomial  $1+x^7+x^{18}$ . The  $y$  sequence is constructed using the polynomial  $1+y^5+y^7+y^{10}+y^{18}$ .

The combined sequence is denoted  $z_0$  in the sequel. Furthermore, let  $x(i)$ ,  $y(i)$  and  $z_0(i)$  denote the  $i^{\text{th}}$  symbol of the sequence  $x$ ,  $y$ , and  $z_0$  respectively. The m-sequences  $x$  and  $y$  are constructed as:

Initial conditions:

- $x$  is constructed with  $x(0) = 1, x(1) = x(2) = \dots = x(16) = x(17) = 0$ .
- $y(0) = y(1) = \dots = y(16) = y(17) = 1$ .

Recursive definition of subsequent symbols:

- $x(i+18) = x(i+7) + x(i) \text{ modulo } 2, i = 0, \dots, 2^{18} - 20$ .
- $y(i+18) = y(i+10) + y(i+7) + y(i+5) + y(i) \text{ modulo } 2, i = 0, \dots, 2^{18}-20$ .

The Gold code sequence is then defined as:

- $z_0(i) = [x(i) \text{ modulo } (2^{18}-1) + y(i)] \text{ modulo } 2, i = 0, \dots, 2^{18}-2$ .

This binary sequence is converted to integer valued sequences  $R_0$  ( $R_0$  assuming values 0, 1, 2, 3) by the following transformation:

- $R_0(i) = 2 z_0((i + 131\,072) \text{ modulo } (2^{18}-1)) + z_0(i) \quad i = 0, 1, \dots, L_{\text{TOT}}$ .

Finally, the complex scrambling code sequence  $C_I(i) + jC_Q(i)$  is defined as:

- $C_I(i) + jC_Q(i) = \exp(j R_0(i) \pi/2), \quad i = 0, 1, \dots, L_{\text{TOT}}$ .

**Table 5.15: Example of sequence scrambling**

$R_0$	$\exp(j R_n \pi/2)$	$I_{\text{scrambled}}$	$Q_{\text{scrambled}}$
0	1	I	Q
1	J	-Q	I
2	-1	-I	-Q
3	-j	Q	-I

Figure 5.25 gives a possible block diagram for PL scrambling sequences generation.

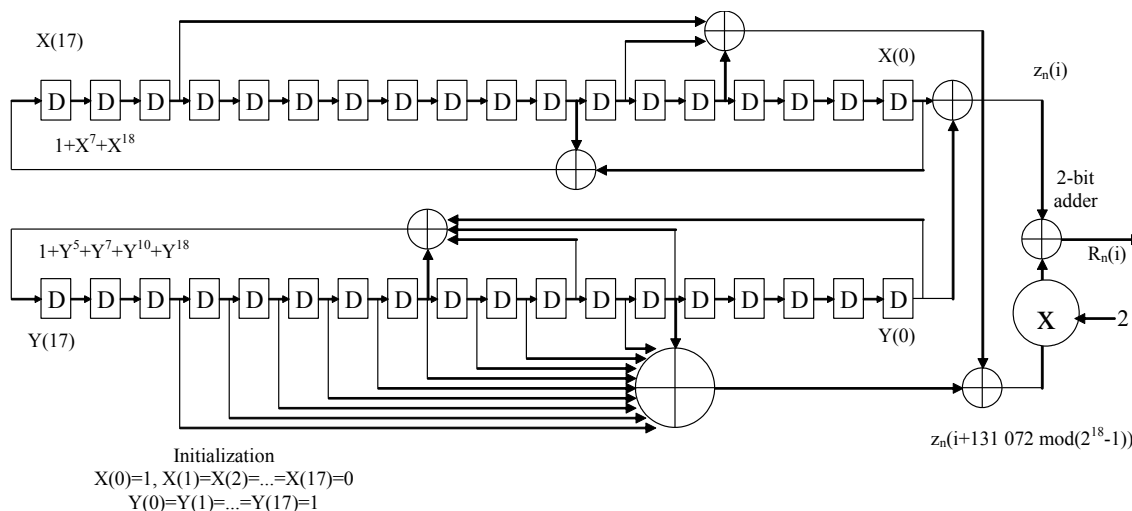

**Figure 5.25: Configuration of PL scrambling code generator**

### 5.6.5 Baseband shaping and quadrature modulation

Spectrum characteristics as defined in clause 5.6 of reference [2] are proposed.

The signals shall be square root raised cosine filtered. The roll-off factor shall be  $\alpha = 0,15, 0,25$  and  $0,35$ .

The baseband square root raised cosine filter shall have a theoretical function defined by the following expression:

$$H(f) = 1 \quad \text{for } |f| < f_N \llcorner -\alpha \rceil$$

$$H(f) = \left\{ \frac{1}{2} + \frac{1}{2} \sin \frac{\pi}{2 f_N} \left[ \frac{f_N - |f|}{\alpha} \right] \right\}^{\frac{1}{2}} \quad \text{for } f_N \llcorner -\alpha \rceil \leq |f| < f_N \llcorner +\alpha \rceil$$

$$H(f) = 0 \quad \text{for } |f| > f_N \llcorner +\alpha \rceil$$

where:  $f_N = \frac{1}{2T_s} = \frac{R_s}{2}$  is the Nyquist frequency and  $\alpha$  is the roll-off factor.

A template for the signal spectrum at the modulator output is given in reference [2].

Quadrature modulation shall be performed by multiplying the in-phase and quadrature samples (after baseband filtering) by  $\sin(2\pi f_0 t)$  and  $\cos(2\pi f_0 t)$ , respectively (where  $f_0$  is the carrier frequency). The two resulting signals shall be added to obtain the modulator output signal.

## 5.7 Multi carrier (OFDM)

Multi Carrier is based on the DVB-T physical layer defined in reference [1]. Three FFT modes are defined by DVB-T: 2k, 4k and 8k.

To cope with reduced signal bandwidth at L-band (channelization of 1,74 MHz), an additional 1k mode is defined. It is a strict downscaling of the existing DVB-T modes.

### 5.7.1 Interface to SH frame

#### 5.7.1.1 CU mapping

The capacity units are aligned to the OFDM symbols. An integer number of CU maps to another integer number of OFDM symbols, dependent on FFT sizes and selected subcarrier modulation. This eases the demapping of the CU and the synchronization of the deinterleaver in the receiver. In any case, the SH frame of 816 CU is always fully aligned with the OFDM frame (see table 5.10).

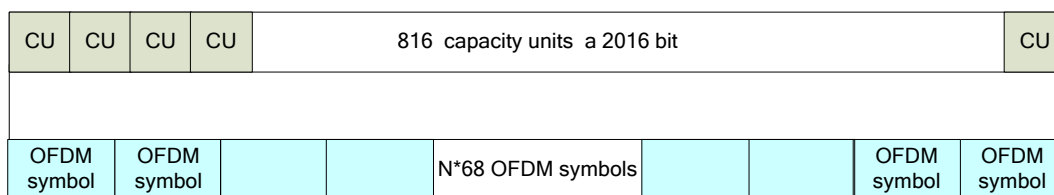

Figure 5.26: Mapping of the SH frame on OFDM

#### 5.7.1.2 Bit demultiplexing

The output of the channel interleaver, which consists of up to two bit streams (in case of hierarchical modulation), is demultiplexed into  $v$  sub-streams, where  $v = 2$  for QPSK,  $v = 4$  for 16-QAM. In non-hierarchical mode, the single input stream is demultiplexed into  $v$  sub-streams. In hierarchical mode the high priority stream is demultiplexed into two sub-streams and the low priority stream is demultiplexed into  $v-2$  sub-streams. This applies in both uniform and non-uniform QAM modes.

The demultiplexing is defined as a mapping of the input bits,  $x_{di}$  onto the output bits  $b_{e,do}$ .

In non-hierarchical mode:

$$x_{di} = b[\text{di}(\text{mod}v](\text{div})(v/2)+2[\text{di}(\text{mod})(v/2)],\text{di}(\text{div})v.$$

In hierarchical mode:

$$x'_{di} = b_{di}(\text{mod}2,\text{di}(\text{div})2$$

$$x''_{di} = b[\text{di}(\text{mod})(v-2)](\text{div})((v-2)/2)+2[\text{di}(\text{mod})((v-2)/2)]+2,\text{di}(\text{div})(v-2)$$

Where:  $x_{di}$  is the input to the demultiplexer in non-hierarchical mode;

$x'_{di}$  is the high priority input to the demultiplexer;

$x''_{di}$  is the low priority input, in hierarchical mode;

$di$  is the input bit number;

- $b_{e, do}$  is the output from the demultiplexer;
- $e$  is the demultiplexed bit stream number ( $0 \leq e < v$ );
- $do$  is the bit number of a given stream at the output of the demultiplexer;
- $\text{mod}$  is the integer modulo operator;
- $\text{div}$  is the integer division operator.

The demultiplexing results in the following mapping:

QPSK:
$x_0$ maps to $b_{0,0}$
$x_1$ maps to $b_{1,0}$

16-QAM non-hierarchical transmission:	16-QAM hierarchical transmission:
$x_0$ maps to $b_{0,0}$	$x'_0$ maps to $b_{0,0}$
$x_1$ maps to $b_{2,0}$	$x'_1$ maps to $b_{1,0}$
$x_2$ maps to $b_{1,0}$	$x''_0$ maps to $b_{2,0}$
$x_3$ maps to $b_{3,0}$	$x''_1$ maps to $b_{3,0}$

The outputs from the demultiplexer are grouped to form  $v$  bit words.

## 5.7.2 Symbol interleaver

The purpose of the symbol interleaver is to map  $v$  bit words onto the 756 (1K mode), 1 512 (2K mode), 3 024 (4K mode) or 6 048 (8K mode) active carriers per OFDM symbol. The symbol interleaver acts on vectors  $Y'$  of 756 (1K mode), 1 512 (2K mode), 3 024 (4K mode) or 6 048 (8K mode) data symbols.

Thus in the 1K mode, a vector  $Y' = (y'_0, y'_1, y'_2, \dots, y'_{755})$  is assembled from 36 groups of 21 data sub words.

In the 2K mode, the 72 groups of 21 words of  $Y'$  form a vector  $Y' = (y'_0, y'_1, y'_2, \dots, y'_{1511})$ .

In the 4K mode, a vector  $Y' = (y'_0, y'_1, y'_2, \dots, y'_{3023})$  is assembled from 144 groups of 21 data sub words.

Similarly in the 8K mode, a vector  $Y' = (y'_0, y'_1, y'_2, \dots, y'_{6047})$  is assembled from 288 groups of 21 data sub words.

The interleaved vector  $Y = (y_0, y_1, y_2, \dots, y_{N_{\max}-1})$  is defined by:

$$y_{H(q)} = y'_q \text{ for even symbols for } q = 0, \dots, N_{\max}-1$$

$$y_q = y'_{H(q)} \text{ for odd symbols for } q = 0, \dots, N_{\max}-1$$

where  $N_{\max} = 756$  in the 1K mode,  $N_{\max} = 1 512$  in the 2K mode,  $N_{\max} = 3024$  in the 4K mode and  $N_{\max} = 6 048$  in the 8K mode.

The symbol index, defining the position of the current OFDM symbol in the OFDM frame, is defined in clause 5.4.7.1.

$H(q)$  is a permutation function defined by the following.

An  $(N_r - 1)$  bit binary word  $R'_i$  is defined, with  $N_r = \log_2 M_{\max}$ , where  $M_{\max} = 1 024$  in the 1K mode,  $M_{\max} = 2 048$  in the 2K mode,  $M_{\max} = 4 096$  in the 4K mode and  $M_{\max} = 8 192$  in the 8K mode, where  $R'_i$  takes the following values:

$$i = 0,1: \quad R'_i [N_r-2, N_r-3, \dots, 1, 0] = 0, 0, \dots, 0, 0;$$

$$i = 2: \quad R'_i [N_r-2, N_r-3, \dots, 1, 0] = 0, 0, \dots, 0, 1;$$

$$2 < i < M_{\max}: \quad \{ R'_i [N_r-3, N_r-4, \dots, 1, 0] = R'_{i-1} [N_r-2, N_r-3, \dots, 2, 1];$$

in the 1K mode:  $R'_i[8] = R'_{i-1}[0] \oplus R'_{i-1}[5]$ ;

in the 2K mode:  $R'_i[9] = R'_{i-1}[0] \oplus R'_{i-1}[3]$ ;

in the 4K mode:  $R'_i[10] = R'_{i-1}[0] \oplus R'_{i-1}[2]$ ;

in the 8K mode:  $R'_i[11] = R'_{i-1}[0] \oplus R'_{i-1}[1] \oplus R'_{i-1}[4] \oplus R'_{i-1}[6]$  }.

A vector  $R_i$  is derived from the vector  $R'_i$  by the bit permutations given in tables 5.16 to 5.19.

**Table 5.16: Bit permutations for the 1K mode**

<b>R'<sub>i</sub> bit positions</b>	8	7	6	5	4	3	2	1	0
<b>R<sub>i</sub> bit positions</b>	7	5	1	8	2	6	0	3	4

**Table 5.17: Bit permutations for the 2K mode**

<b>R'<sub>i</sub> bit positions</b>	9	8	7	6	5	4	3	2	1	0
<b>R<sub>i</sub> bit positions</b>	0	7	5	1	8	2	6	9	3	4

**Table 5.18: Bit permutations for the 4K mode**

<b>R'<sub>i</sub> bit positions</b>	10	9	8	7	6	5	4	3	2	1	0
<b>R<sub>i</sub> bit positions</b>	7	10	5	8	1	2	4	9	0	3	6

**Table 5.19: Bit permutations for the 8K mode**

<b>R'<sub>i</sub> bit positions</b>	11	10	9	8	7	6	5	4	3	2	1	0
<b>R<sub>i</sub> bit positions</b>	5	11	3	0	10	8	6	9	2	4	1	7

The permutation function  $H(q)$  is defined by the following algorithm:

```

q = 0;
for (i = 0; i < Mmax; i = i + 1)
{
  H(q) = (i mod 2) × 2Nr-1 + ∑j=0Nr-2 Ri(j) × 2j;
  if (H(q) < Nmax) q = q+1;
}

```

A schematic block diagram of the algorithm used to generate the permutation function is represented in figures 5.27 to 5.30 for the 1K, 2K, 4K and 8K mode.

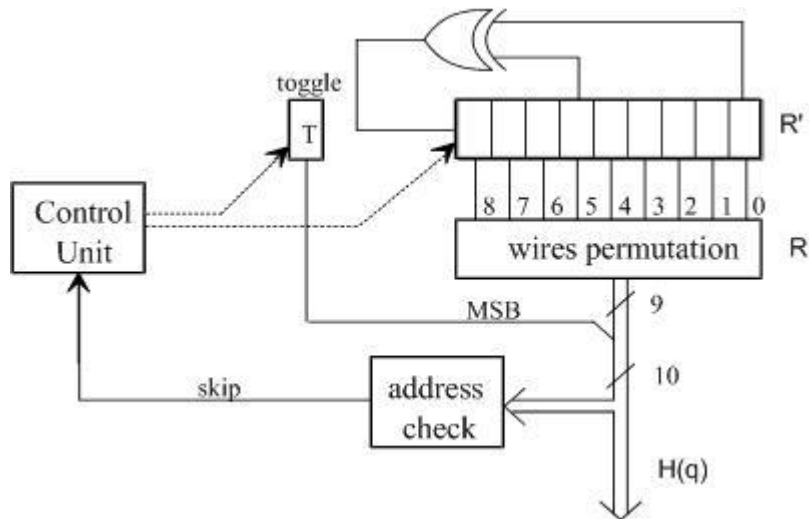

Figure 5.27: Symbol interleaver address generation scheme for the 1K mode

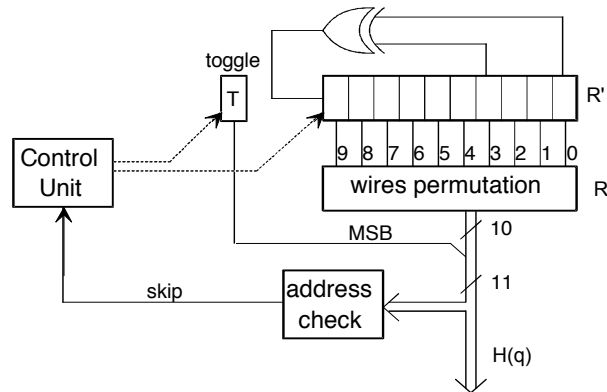

Figure 5.28: Symbol interleaver address generation scheme for the 2K mode

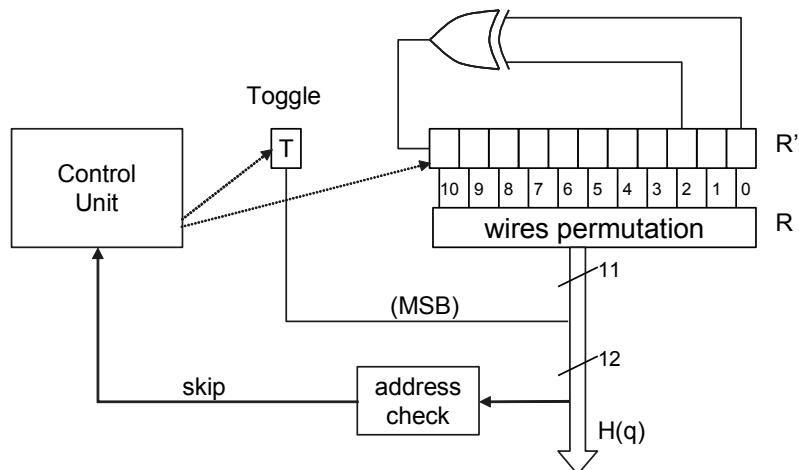
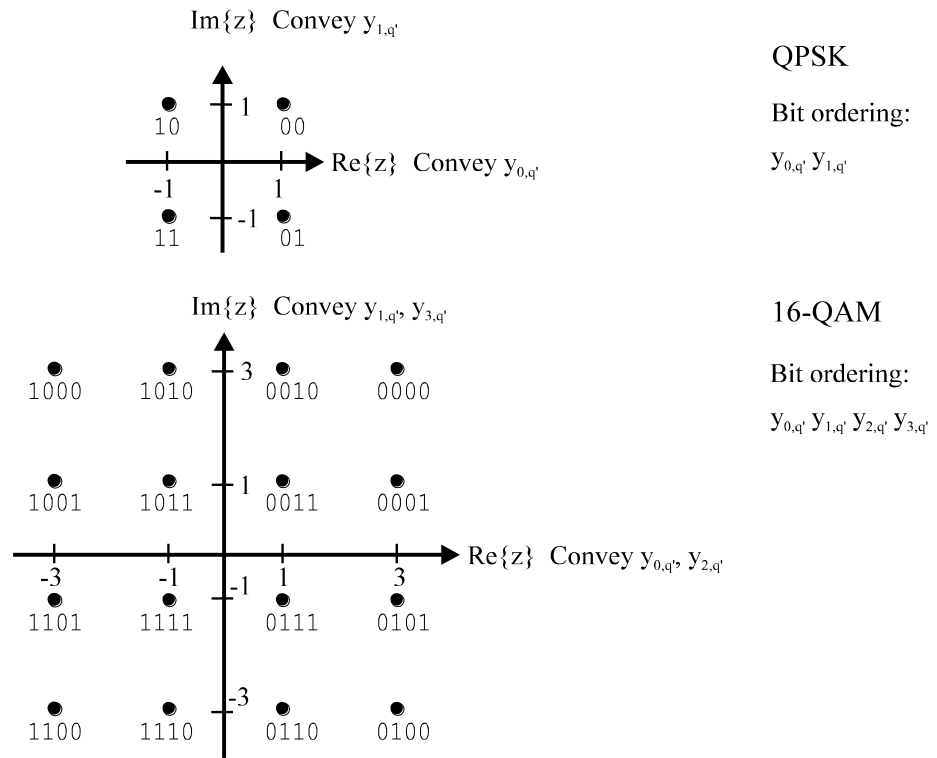

Figure 5.29: Symbol interleaver address generation scheme for the 4K mode





**Figure 5.31: The QPSK, 16-QAM mappings and the corresponding bit patterns (non-hierarchical, and hierarchical with  $\alpha = 1$ )**

The  $y_{u,q}$  denote the bits representing a complex modulation symbol  $z$ .

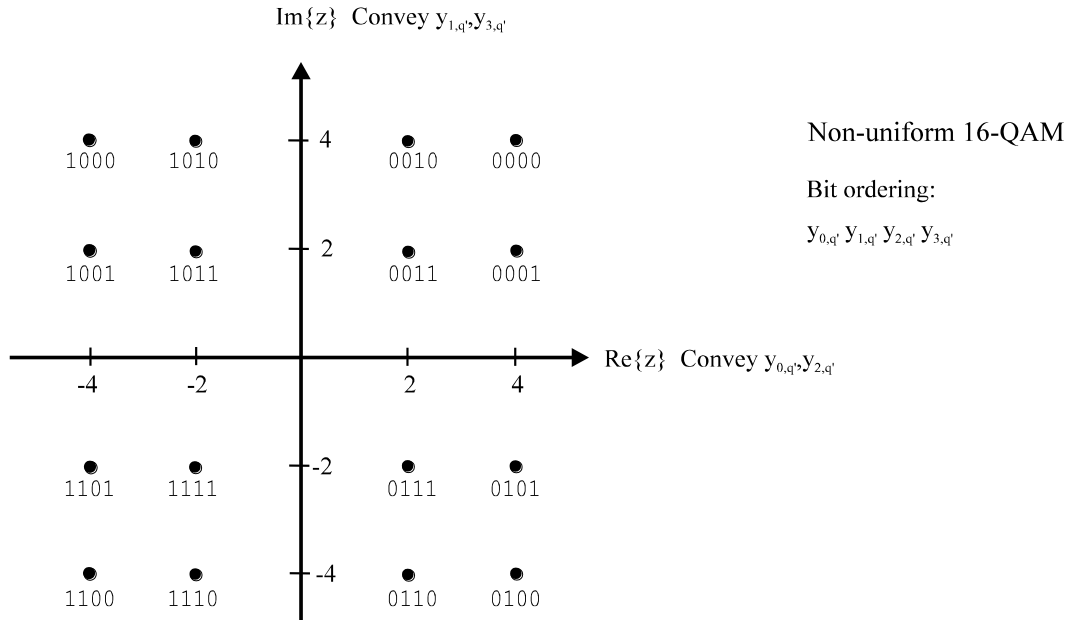

**Figure 5.32: Non-uniform 16-QAM mappings with  $\alpha = 2$**

The  $y_{u,q}$  denote the bits representing a complex modulation symbol  $z$ .

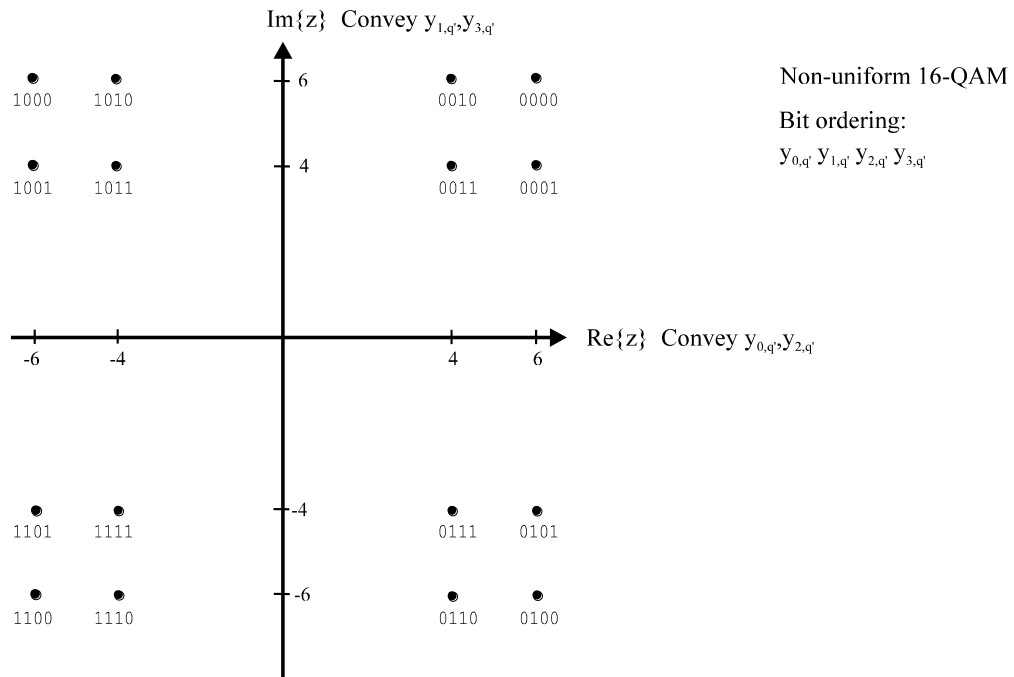

**Figure 5.33: Non-uniform 16-QAM mappings with  $\alpha = 4$**

The  $y_{u,q}$  denote the bits representing a complex modulation symbol  $z$ .

Non-hierarchical transmission:

- The data bit stream at the output of the Interleaver is mapped onto a complex number  $z$ , according to figure 5.31.

Hierarchical transmission:

- In the case of hierarchical transmission, the two data streams are mapped as shown in figures 5.31 to 5.33, as appropriate.

For hierarchical 16QAM:

- The high priority bits are the  $y_{0,q}$  and  $y_{1,q}$  bits. The low priority bits are the  $y_{2,q}$  and  $y_{3,q}$  bits. The mappings of figures 5.31 to 5.33 are applied, as appropriate. For example, the top left constellation point, corresponding to 1 000 represents  $y_{0,q} = 1, y_{1,q} = y_{2,q} = y_{3,q} = 0$ . If this constellation is decoded as if it were QPSK, the high priority bits,  $y_{0,q}, y_{1,q}$  will be deduced. To decode the low priority bits, the full constellation shall be examined and the appropriate bits ( $y_{2,q}, y_{3,q}$ ) extracted from  $y_{0,q}, y_{1,q}, y_{2,q}, y_{3,q}$ .

## 5.7.4 OFDM framing

### 5.7.4.1 OFDM frame structure

The transmitted signal is organized in frames. Each frame has duration of  $T_F$ , and consists of 68 OFDM symbols. Four frames constitute one super-frame. Each symbol is constituted by a set of  $K = 6\ 817$  carriers in the 8k mode, of  $K = 3\ 409$  carriers in the 4k mode, of  $K = 1\ 705$  carriers in the 2k mode, and  $K = 853$  carriers in the 1k mode, and transmitted with a duration  $T_S$ . It is composed of two parts: a useful part with duration  $T_U$  and a guard interval with duration  $\Delta$ . The guard interval consists in a cyclic continuation of the useful part,  $T_U$ , and is inserted before it. Four values of guard intervals may be used.

The symbols in an OFDM frame are numbered from 0 to 67. All symbols contain data and reference information.

Since the OFDM signal comprises many separately modulated carriers, each symbol can in turn be considered to be divided into cells, each corresponding to the modulation carried on one carrier during one symbol.

In addition to the transmitted data an OFDM frame contains:

- Scattered pilot cells
- Continual pilot carriers
- TPS carriers

The pilots can be used for frame synchronization, frequency synchronization, time synchronization, channel estimation, transmission mode identification and can also be used to follow the phase noise.

The carriers are indexed by  $k \in [K_{\min}; K_{\max}]$  and determined by  $K_{\min} = 0$  and  $K_{\max} = 1\,704$  in 2k mode, 3 408 in 4k mode, 6 816 in 8k mode and 852 in 1k mode respectively. The spacing between adjacent carriers is  $1/T_U$  while the spacing between carriers  $K_{\min}$  and  $K_{\max}$  are determined by  $(K-1)/T_U$ .

The values for the various time-related parameters are given in multiples of the elementary period  $T$  and in microseconds. The elementary period  $T$  is  $7/64 \mu\text{s}$  for 8 MHz channels,  $1/8 \mu\text{s}$  for 7 MHz channels,  $7/48 \mu\text{s}$  for 6 MHz channels,  $7/40 \mu\text{s}$  for 5 MHz channels and  $7/12,8 \mu\text{s}$  for 1,7 MHz channel.

The emitted signal is described by the following expression:

$$s(t) = \text{Re} \left\{ e^{j2\pi f_c t} \sum_{m=0}^{\infty} \sum_{l=0}^{67} \sum_{k=K_{\min}}^{K_{\max}} c_{m,l,k} \times \psi_{m,l,k}(t) \right\}$$

$$\text{where } \psi_{m,l,k}(t) = \begin{cases} e^{j2\pi \frac{k}{T_U} (t - \Delta - l \times T_S - 68 \times m \times T_S)} & (l + 68 \times m) \times T_S \leq t \leq (l + 68 \times m + 1) \times T_S \\ 0 & \text{else} \end{cases}$$

where:

$k$	denotes the carrier number;
$l$	denotes the OFDM symbol number;
$m$	denotes the transmission frame number;
$K$	is the number of transmitted carriers;
$T_S$	is the symbol duration;
$T_U$	is the inverse of the carrier spacing;
$\Delta$	is the duration of the guard interval;
$f_c$	is the central frequency of the RF signal;
$k'$	is the carrier index relative to the centre frequency, $k' = k - (K_{\max} + K_{\min}) / 2$ ;
$c_{m,0,k}$	complex symbol for carrier $k$ of the Data symbol no. 1 in frame number $m$ ;
$c_{m,1,k}$	complex symbol for carrier $k$ of the Data symbol no. 2 in frame number $m$ ;
...	
$c_{m,67,k}$	complex symbol for carrier $k$ of the Data symbol no. 68 in frame number $m$ .

The  $c_{m,l,k}$  values are normalized modulation values of the constellation point  $z$  (see figures 5.31 to 5.33) according to the modulation alphabet used for the data. The normalization factors yield  $E[c \times c^*] = 1$  and are shown in table 5.20.

**Table 5.20: Normalization factors for data symbols**

Modulation scheme		Normalization factor
QPSK		$c = z/\sqrt{2}$
16-QAM non-hierarch.	$\alpha = 1$	$c = z/\sqrt{10}$
16-QAM hierarch.	$\alpha = 2$	$c = z/\sqrt{20}$
16-QAM hierarch.	$\alpha = 4$	$c = z/\sqrt{52}$

The numerical values for the OFDM parameters for the 8k, 4k, 2k and 1k modes are given in tables 5.21 and 5.22 for 8 MHz channels. The elementary period  $T$  is  $7/64 \mu\text{s}$  for 8 MHz channels.

**Table 5.21: Numerical values for the OFDM parameters for all modes for 8 MHz channels**

Parameter	8k mode	2k mode
Number of carriers $K$	6 817	1 705
Value of carrier number $K_{\min}$	0	0
Value of carrier number $K_{\max}$	6 816	1 704
Duration $T_U$ (see note 2)	<b><i>896 <math>\mu\text{s}</math></i></b>	<b><i>224 <math>\mu\text{s}</math></i></b>
Carrier spacing $1/T_U$ (see note)	<b><i>1 116 Hz</i></b>	<b><i>4 464 Hz</i></b>
Spacing between carriers $K_{\min}$ and $K_{\max}$ $(K-1)/T_U$	<b><i>7,61 MHz</i></b>	<b><i>7,61 MHz</i></b>

Parameter	4k mode	1k mode
Number of carriers $K$	3 409	853
Value of carrier number $K_{\min}$	0	0
Value of carrier number $K_{\max}$	3 408	852
Duration $T_U$ (see note 2)	<b><i>448 <math>\mu\text{s}</math></i></b>	<b><i>112 <math>\mu\text{s}</math></i></b>
Carrier spacing $1/T_U$ (see note)	<b><i>2 232 Hz</i></b>	<b><i>8 929 Hz</i></b>
Spacing between carriers $K_{\min}$ and $K_{\max}$ $(K-1)/T_U$	<b><i>7,61 MHz</i></b>	<b><i>7,61 MHz</i></b>

NOTE: Values in bold and italics are approximate values.

**Table 5.22: Duration of symbol part for the allowed guard intervals for 8 MHz channels**

Mode	8k mode				2k mode			
	1/4	1/8	1/16	1/32	1/4	1/8	1/16	1/32
Guard interval $\Delta/T_U$								
Duration of symbol part $T_U$	8 192 $\times T$ 896 $\mu\text{s}$				2 048 $\times T$ 224 $\mu\text{s}$			
Duration of guard interval $\Delta$	2 048 $\times T$ 224 $\mu\text{s}$	1 024 $\times T$ 112 $\mu\text{s}$	512 $\times T$ 56 $\mu\text{s}$	256 $\times T$ 28 $\mu\text{s}$	512 $\times T$ 56 $\mu\text{s}$	256 $\times T$ 28 $\mu\text{s}$	128 $\times T$ 14 $\mu\text{s}$	64 $\times T$ 7 $\mu\text{s}$
Symbol duration $T_S = \Delta + T_U$	10 240 $\times T$ 1 120 $\mu\text{s}$	9 216 $\times T$ 1 008 $\mu\text{s}$	8 704 $\times T$ 952 $\mu\text{s}$	8 448 $\times T$ 924 $\mu\text{s}$	2 560 $\times T$ 280 $\mu\text{s}$	2 304 $\times T$ 252 $\mu\text{s}$	2 176 $\times T$ 238 $\mu\text{s}$	2 112 $\times T$ 231 $\mu\text{s}$

Mode	4k mode				1k mode			
	1/4	1/8	1/16	1/32	1/4	1/8	1/16	1/32
Guard interval $\Delta/T_U$								
Duration of symbol part $T_U$	4 096 $\times T$ 448 $\mu\text{s}$				1 024 $\times T$ 112 $\mu\text{s}$			
Duration of guard interval $\Delta$	1 024 $\times T$ 112 $\mu\text{s}$	512 $\times T$ 56 $\mu\text{s}$	256 $\times T$ 28 $\mu\text{s}$	128 $\times T$ 14 $\mu\text{s}$	256 $\times T$ 28 $\mu\text{s}$	128 $\times T$ 14 $\mu\text{s}$	64 $\times T$ 7 $\mu\text{s}$	32 $\times T$ 3.5 $\mu\text{s}$
Symbol duration $T_S = \Delta + T_U$	5 120 $\times T$ 560 $\mu\text{s}$	4 608 $\times T$ 504 $\mu\text{s}$	4 352 $\times T$ 476 $\mu\text{s}$	4 224 $\times T$ 462 $\mu\text{s}$	1 280 $\times T$ 140 $\mu\text{s}$	1 152 $\times T$ 126 $\mu\text{s}$	1 088 $\times T$ 119 $\mu\text{s}$	1 056 $\times T$ 115,5 $\mu\text{s}$

The numerical values for the OFDM parameters for the 8k, 4k, 2k and 1k modes are given in tables 5.23 and 5.24 for 5 MHz channels. The elementary period  $T$  is  $7/40 \mu\text{s}$  for 5 MHz channels.

**Table 5.23: Numerical values for the OFDM parameters all modes for 5 MHz channels**

Parameter	8k mode	2k mode
Number of carriers K	6 817	1 705
Value of carrier number $K_{\min}$	0	0
Value of carrier number $K_{\max}$	6 816	1 704
Duration $T_U$ (see note)	<b><i>1 433,6 <math>\mu</math>s</i></b>	<b><i>358,40 <math>\mu</math>s</i></b>
Carrier spacing $1/T_U$ (see note)	<b><i>698 Hz</i></b>	<b><i>2 790 Hz</i></b>
Spacing between carriers $K_{\min}$ and $K_{\max}$ $(K-1)/T_U$	<b><i>4,75 MHz</i></b>	<b><i>4,75 MHz</i></b>

Parameter	4k mode	1k mode
Number of carriers K	3 409	853
Value of carrier number $K_{\min}$	0	0
Value of carrier number $K_{\max}$	3408	852
Duration $T_U$ (see note 2)	<b><i>716,8 <math>\mu</math>s</i></b>	<b><i>179,2 <math>\mu</math>s</i></b>
Carrier spacing $1/T_U$ (see note)	<b><i>1 395 Hz</i></b>	<b><i>5 580 Hz</i></b>
Spacing between carriers $K_{\min}$ and $K_{\max}$ $(K-1)/T_U$	<b><i>4,75 MHz</i></b>	<b><i>4,75 MHz</i></b>

NOTE: Values in bold and italics are approximate values.

**Table 5.24: Duration of symbol part for the allowed guard intervals for 5 MHz channels**

Mode	8k mode				2k mode			
	1/4	1/8	1/16	1/32	1/4	1/8	1/16	1/32
Guard interval $\Delta/T_U$								
Duration of symbol part $T_U$	8 192 $\times$ T 1433,6 $\mu$ s				2 048 $\times$ T 358,4 $\mu$ s			
Duration of guard interval $\Delta$	2 048 $\times$ T 358,4 $\mu$ s	1 024 $\times$ T 179,2 $\mu$ s	512 $\times$ T 89,6 $\mu$ s	256 $\times$ T 44,8 $\mu$ s	512 $\times$ T 89,6 $\mu$ s	256 $\times$ T 44,8 $\mu$ s	128 $\times$ T 22,4 $\mu$ s	64 $\times$ T 11,2 $\mu$ s
Symbol duration $T_S = \Delta + T_U$	10 240 $\times$ T 1 792 $\mu$ s	9 216 $\times$ T 1 612,8 $\mu$ s	8 704 $\times$ T 1 523,2 $\mu$ s	8 448 $\times$ T 1 478,4 $\mu$ s	2 560 $\times$ T 448 $\mu$ s	2 304 $\times$ T 403,2 $\mu$ s	2 176 $\times$ T 380,8 $\mu$ s	2 112 $\times$ T 369,6 $\mu$ s

Mode	4k mode				1k mode			
	1/4	1/8	1/16	1/32	1/4	1/8	1/16	1/32
Guard interval $\Delta/T_U$								
Duration of symbol part $T_U$	4 096 $\times$ T 716,8 $\mu$ s				1 024 $\times$ T 179,2 $\mu$ s			
Duration of guard interval $\Delta$	1 024 $\times$ T 179,2 $\mu$ s	512 $\times$ T 89,6 $\mu$ s	256 $\times$ T 44,8 $\mu$ s	128 $\times$ T 22,4 $\mu$ s	256 $\times$ T 44,8 $\mu$ s	128 $\times$ T 22,4 $\mu$ s	64 $\times$ T 11,2 $\mu$ s	32 $\times$ T 5,6 $\mu$ s
Symbol duration $T_S = \Delta + T_U$	5 120 $\times$ T 896 $\mu$ s	4 608 $\times$ T 806,4 $\mu$ s	4 352 $\times$ T 761,6 $\mu$ s	4 224 $\times$ T 739,2 $\mu$ s	1 280 $\times$ T 224 $\mu$ s	1 152 $\times$ T 201,6 $\mu$ s	1 088 $\times$ T 190,4 $\mu$ s	1 056 $\times$ T 184,8 $\mu$ s

The numerical values for the OFDM parameters for the 1k mode are given in tables 5.25 and 5.26 for 1,7 MHz channels. The elementary period T is 7/12,8  $\mu$ s for 1,7 MHz channels.

**Table 5.25: Numerical values for the OFDM parameters for the 1k mode for 1,7 MHz channels**

Parameter	1k mode
Number of carriers K	853
Value of carrier number $K_{\min}$	0
Value of carrier number $K_{\max}$	852
Duration $T_U$	560 $\mu$ s
Carrier spacing $1/T_U$	<b><i>1 786 Hz</i></b>
Spacing between carriers $K_{\min}$ and $K_{\max}$ $(K-1)/T_U$	<b><i>1,52 MHz</i></b>

NOTE: Values in italics are approximate values.

**Table 5.26: Duration of symbol part for the allowed guard intervals for 1,7 MHz channels**

Mode	1k mode			
	1/4	1/8	1/16	1/32
Guard interval $\Delta/T_U$	1/4	1/8	1/16	1/32
Duration of symbol part $T_U$	1 024 × T 560 μs			
Duration of guard interval $\Delta$	256 × T 140 μs	128 × T 70 μs	64 × T 35 μs	32 × T 17,5 μs
Symbol duration $T_S = \Delta + T_U$	1 280 × T 700 μs	1 152 × T 630 μs	1 088 × T 595 μs	1 056 × T 577,5 μs

### 5.7.4.2 Reference signals

Reference signals as defined in clause 4.5 of reference [1] are used for modes 2k, 4k and 8k.

This clause specifies the mode independent reference signals processes and the parameters to use for the 8k, 4k, 2k and 1k transmission modes.

#### 5.7.4.2.1 Functions and derivation

Various cells within the OFDM frame are modulated with reference information whose transmitted value is known to the receiver. Cells containing reference information are transmitted at "boosted" power level (see clause 5.7.4.2.5). The information transmitted in these cells is scattered or continual pilot cells.

Each continual pilot coincides with a scattered pilot every fourth symbol; the number of useful data carriers is constant from symbol to symbol: 756 useful carriers in 1k mode, 1 512 useful carriers in 2k mode, 3 024 useful carriers in 4k mode and 6 048 useful carriers in 8k mode.

The value of the scattered or continual pilot information is derived from a Pseudo Random Binary Sequence (PRBS), which is a series of values, one for each of the transmitted carriers (see clause 5.7.4.2.2).

#### 5.7.4.2.2 Definition of reference sequence

The continual and scattered pilots are modulated according to a PRBS sequence,  $w_k$ , corresponding to their respective carrier index  $k$ . This sequence also governs the starting phase of the TPS information (described in clause 5.7.4.3).

The PRBS sequence is generated according to figure 5.34.

The PRBS is initialized so that the first output bit from the PRBS coincides with the first active carrier. A new value is generated by the PRBS on every carrier (whether or not it is a pilot).

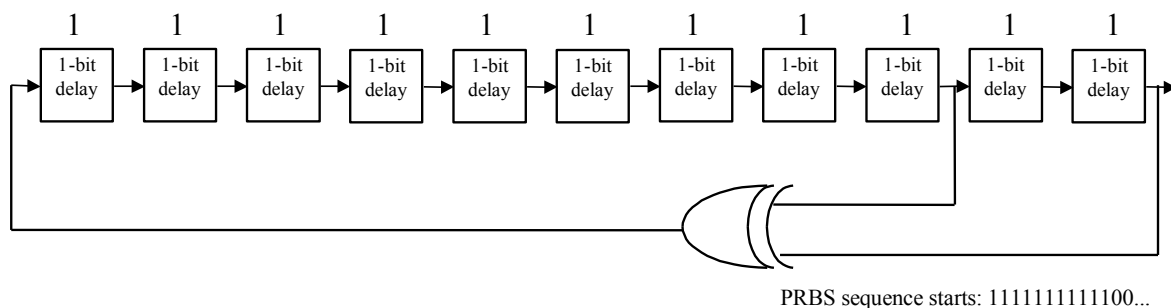
**Figure 5.34: Generation of PRBS sequence**

The polynomial for the Pseudo Random Binary Sequence (PRBS) generator shall be:

$$X^{11} + X^2 + 1 \text{ (figure 5.34)}$$

### 5.7.4.2.3 Location of scattered pilot cells

Reference information, taken from the reference sequence, is transmitted in scattered pilot cells in every symbol. Scattered pilot cells are always transmitted at the "boosted" power level (see clause 5.7.4.2.5). Thus the corresponding modulation is given by:

- $\text{Re}\{c_{m,l,k}\} = 4 / 3 \times 2 (1/2 - w_k)$
- $\text{Im}\{c_{m,l,k}\} = 0$

Where  $m$  is the frame index,  $k$  is the frequency index of the carriers and  $l$  is the time index of the symbols.

For the symbol of index  $l$  (ranging from 0 to 67), carriers for which index  $k$  belongs to the subset  $\{k = K_{\min} + 3 \times (l \bmod 4) + 12p \mid p \text{ integer}, p \geq 0, k \in [K_{\min}; K_{\max}]\}$  are scattered pilots.  $p$  is an integer that takes all possible values greater than or equal to zero, provided that the resulting value for  $k$  does not exceed the valid range  $[K_{\min}; K_{\max}]$ .

The pilot insertion pattern is shown in figure 5.35.

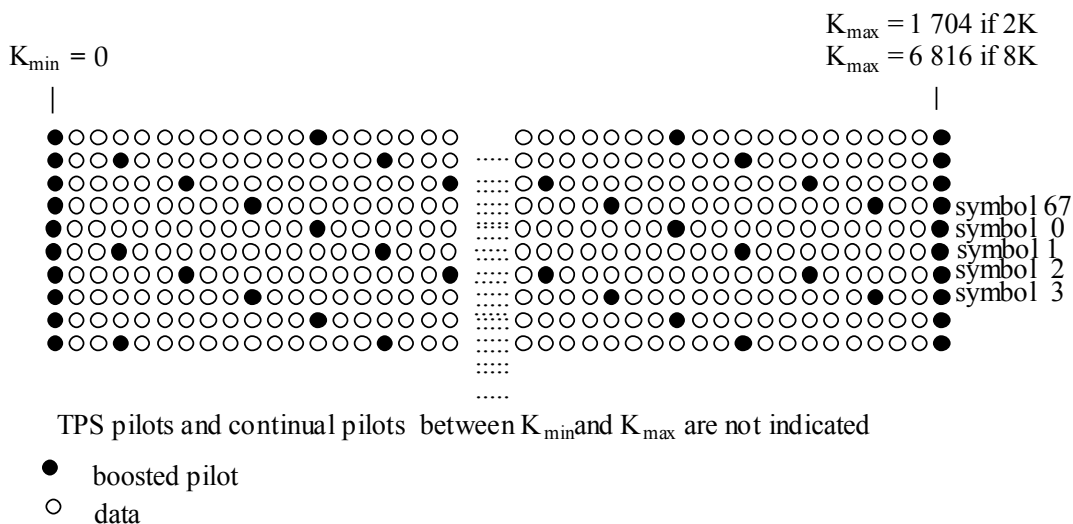

**Figure 5.35: Frame structure**

### 5.7.4.2.4 Location of continual pilot carriers

In addition to the scattered pilots described above, 177 continual pilots in the 8k mode, 89 in the 4k mode, 45 in the 2k mode, and 25 in the 1k mode are inserted according to table 5.27.

Table 5.27: Carrier indices for continual pilot carriers

Continual pilot carrier positions (index number k)													
2k mode							8k mode						
0	48	54	87	141	156	192	0	48	54	87	141	156	192
201	255	279	282	333	432	450	201	255	279	282	333	432	450
483	525	531	618	636	714	759	483	525	531	618	636	714	759
765	780	804	873	888	918	939	765	780	804	873	888	918	939
942	969	984	1 050	1 101	1 107	1 110	942	969	984	1 050	1 101	1 107	1 110
1 137	1 140	1 146	1 206	1 269	1 323	1 377	1 137	1 140	1 146	1 206	1 269	1 323	1 377
1 491	1 683	1 704					1 491	1 683	1 704	1 752	1 758	1 791	1 845
							1 860	1 896	1 905	1 959	1 983	1 986	2 037
							2 136	2 154	2 187	2 229	2 235	2 322	2 340
							2 418	2 463	2 469	2 484	2 508	2 577	2 592
							2 622	2 643	2 646	2 673	2 688	2 754	2 805
							2 811	2 814	2 841	2 844	2 850	2 910	2 973
							3 027	3 081	3 195	3 387	3 408	3 456	3 462
							3 495	3 549	3 564	3 600	3 609	3 663	3 687
							3 690	3 741	3 840	3 858	3 891	3 933	3 939
							4 026	4 044	4 122	4 167	4 173	4 188	4 212
							4 281	4 296	4 326	4 347	4 350	4 377	4 392
							4 458	4 509	4 515	4 518	4 545	4 548	4 554
							4 614	4 677	4 731	4 785	4 899	5 091	5 112
							5 160	5 166	5 199	5 253	5 268	5 304	5 313
							5 367	5 391	5 394	5 445	5 544	5 562	5 595
							5 637	5 643	5 730	5 748	5 826	5 871	5 877
							5 892	5 916	5 985	6 000	6 030	6 051	6 054
							6 081	6 096	6 162	6 213	6 219	6 222	6 249
							6 252	6 258	6 318	6 381	6 435	6 489	6 603
							6 795	6 816					

Continual pilots carrier positions for 4K mode (index number k)												
0	48	54	87	141	156	192	201	255	279	282	333	
432	450	483	525	531	618	636	714	759	765	780	804	
873	888	918	939	942	969	984	1 050	1 101	1 107	1 110	1 137	
1 140	1 146	1 206	1 269	1 323	1 377	1 491	1 683	1 704	1 752	1 758	1 791	
1 845	1 860	1 896	1 905	1 959	1 983	1 986	2 037	2 136	2 154	2 187	2 229	
2 235	2 322	2 340	2 418	2 463	2 469	2 484	2 508	2 577	2 592	2 622	2 643	
2 646	2 673	2 688	2 754	2 805	2 811	2 814	2 841	2 844	2 850	2 910	2 973	
3 027	3 081	3 195	3 387	3 408								

Continual pilot carrier positions (index number k)							
1k mode							
0	48	54	87	141	156	192	
201	255	279	282	333	432	450	
483	525	531	618	636	714	759	
765	786	813	852				

All continual pilots are modulated according to the reference sequence, see clause 5.7.4.2.2.

The continual pilots are transmitted at "boosted" power level.

Thus the corresponding modulation is given by:

- $\text{Re}\{c_{m,l,k}\} = 4/3 \times 2(1/2 - w_k)$
- $\text{Im}\{c_{m,l,k}\} = 0$

### 5.7.4.2.5 Amplitudes of all reference information

As explained in clause 5.7.4.2.2 the modulation of all data cells is normalized so that  $E[c \times c^*] = 1$ .

All cells which are continual or scattered pilots, i.e. they are members of the sets defined in clauses 5.7.4.2.2 or 5.7.4.2.2, are transmitted at boosted power so that for these  $E[c \times c^*] = 16/9$ .

### 5.7.4.3 Transmission Parameter Signalling (TPS)

This clause specifies the Transmission Parameter Signalling (TPS). DVB-SH TPS reuses the TPS structure specified in reference [1]. Compatibility is ensured via non-modification of most important parameters including modulation, hierarchy information, guard interval and transmission mode, Frame number in a super-frame and cell identification. Signalling of DVB-T including options covering 4k, in-depth inner interleaver, time-slicing and MPE-FEC bits for DVB-H signalling are then used. However, if the DVB-SH selector bit is set to 1, other remaining fields specified in [1] are superseded by the present document that gives actual code rates, time interleaver configuration and super frame number within an SH frame.

The TPS is transmitted in parallel on 7 TPS carriers in 1k mode, 17 carriers for the 2k mode, on 34 carriers for the 4k mode and on 68 carriers for the 8k mode.

Every TPS carrier in the same symbol conveys the same differentially encoded information bit. The following carrier indices contain TPS carriers:

**Table 5.28: Carrier indices for TPS carriers**

2k mode					8k mode							
34	50	209	346	413	34	50	209	346	413	569	595	688
569	595	688	790	901	790	901	1 073	1 219	1 262	1 286	1 469	1 594
1 073	1 219	1 262	1 286	1 469	1 687	1 738	1 754	1 913	2 050	2 117	2 273	2 299
1 594	1 687				2 392	2 494	2 605	2 777	2 923	2 966	2 990	3 173
					3 298	3 391	3 442	3 458	3 617	3 754	3 821	3 977
					4 003	4 096	4 198	4 309	4 481	4 627	4 670	4 694
					4 877	5 002	5 095	5 146	5 162	5 321	5 458	5 525
					5 681	5 707	5 800	5 902	6 013	6 185	6 331	6 374
					6 398	6 581	6 706	6 799				

TPS carrier indices for 4K mode												
34	50	209	346	413	569	595	688	790	901	1 073	1 219	
1 262	1 286	1 469	1 594	1 687	1 738	1 754	1 913	2 050	2 117	2 273	2 299	
2 392	2 494	2 605	2 777	2 923	2 966	2 990	3 173	3 298	3 391			

1k mode			
34	209	346	413
569	688	790	

The TPS carriers convey information on:

- modulation including the  $\alpha$  value of the QAM constellation pattern (see note);
- hierarchy information;
- guard interval;
- transmission mode (1k, 2k, 4k, 8k);
- Frame number in a super-frame;
- cell identification;
- DVB-SH mode (selector bit);
- code rates;

- i) Time interleaver configuration;
- j) Super frame number in a SH frame.

NOTE: The  $\alpha$  value defines the modulation based on the cloud spacing of a generalized QAM constellation. It allows specification of uniform and non-uniform modulation schemes, covering QPSK and 16-QAM.

### 5.7.4.3.1 Scope of the TPS

The TPS is defined over 68 consecutive OFDM symbols, referred to as one OFDM frame. Four consecutive frames correspond to one OFDM super-frame. Several consecutive super frames correspond to one DVB-SH frame.

The reference sequence corresponding to the TPS carriers of the first symbol of each OFDM frame is used to initialize the TPS modulation on each TPS carrier (see clause 5.7.4.3.3).

Each OFDM symbol conveys one TPS bit. Each TPS block (corresponding to one OFDM frame) contains 68 bits, defined as follows:

- 1 initialization bit;
- 16 synchronization bits;
- 37 information bits;
- 14 redundancy bits for error protection.

All 37 information bits are used.

### 5.7.4.3.2 TPS transmission format

The transmission parameter information shall be transmitted as shown in table 5.29 while details are given in following clauses (left most bit or MSB is sent first).

**Table 5.29: TPS signalling information and format**

Bit number	Format	Purpose/Content
$s_0$	see clause 5.7.4.3.2.1	Initialization
$s_1$ to $s_{16}$	0011010111101110 or 1100101000010001	Synchronization word
$s_{17}$ to $s_{22}$	See 5.7.4.3.2.3	Length indicator
$s_{23}$ , $s_{24}$	See table 5.30	Frame number
$s_{25}$ , $s_{26}$	See table 5.31	Constellation
$s_{27}$ , $s_{28}$ , $s_{29}$	See table 5.32	Hierarchy information
$s_{30}$ , $s_{31}$ , $s_{32}$ , $s_{33}$	See 5.7.4.3.2.7	Code rate, HP/LP stream or interleaver configuration
$s_{34}$	See 5.7.4.3.2.13	interleaver configuration
$s_{35}$	See 5.7.4.3.2.8	Super Frame number
$s_{36}$ , $s_{37}$	See table 5.35	Guard interval
$s_{38}$ , $s_{39}$	See table 5.36	Transmission mode
$s_{40}$ to $s_{47}$	See 5.7.4.3.2.11	Cell identifier
$s_{48}$ to $s_{52}$	See 5.6.4.3.2.13	Interleaver configuration
$s_{53}$	See 5.7.4.3.2.12	DVB-SH mode
$s_{54}$ to $s_{67}$	BCH code	Error protection

The TPS information transmitted in super-frame  $m'$  bits  $s_{25}$  -  $s_{34}$  and  $s_{36}$  -  $s_{39}$  and  $s_{48}$  -  $s_{52}$  always apply to super-frame  $m' + 1$ , whereas all other bits refer to super-frame  $m'$ .

#### 5.7.4.3.2.1 Initialization

The first bit,  $s_0$ , is an initialization bit for the differential 2-PSK modulation. The modulation of the TPS initialization bit is derived from the PRBS sequence defined in clause 5.7.4.2.2. This process is described in clause 5.7.4.3.3.

#### 5.7.4.3.2.2 Synchronization

Bits 1 to 16 of the TPS are a synchronization word.

The first and third TPS block in each super-frame has the following synchronization word:

$$s_1 - s_{16} = 0011010111101110.$$

The second and fourth TPS block has the following synchronization word:

$$s_1 - s_{16} = 1100101000010001.$$

#### 5.7.4.3.2.3 TPS length indicator

The first 6 bits of the TPS information is used as a TPS length indicator (binary count starting from and including bit  $s_{17}$ ) to signal the number of used bits of the TPS.

The transmission of the Cell Identification (see clause 5.7.4.3.2.11) is mandatory when in DVB-SH mode. The value of the TPS length indicator shall be "100101" (37 TPS bits in use).

#### 5.7.4.3.2.4 Frame number

Four frames constitute one super-frame. The frames inside the super-frame are numbered from 1 to 4. The mapping from bits  $s_{23}$ ,  $s_{24}$  to the frame number is given in table 5.30.

**Table 5.30: Signalling format for frame number**

Bits $s_{23}$ , $s_{24}$	Frame number
00	Frame number 1 in the super-frame
01	Frame number 2 in the super-frame
10	Frame number 3 in the super-frame
11	Frame number 4 in the super-frame

#### 5.7.4.3.2.5 Constellation

The constellation shall be signalled by 2 bits according to table 5.31. In order to determine the modulation scheme, the receiver shall also decode the hierarchy information given in table 5.32.

**Table 5.31: Signalling format for the possible constellation patterns**

Bits $s_{25}$ , $s_{26}$	Constellation characteristics
00	QPSK
01	16-QAM
10	Reserved (see reference [1])
11	Reserved

#### 5.7.4.3.2.6 Hierarchy information

The hierarchy information specifies whether the transmission is hierarchical and, if so, what the  $\alpha$  value is. The 16QAM constellation diagrams which correspond to various  $\alpha$  values are shown in figure 5.31 to figure 5.33. Where  $\alpha$  is signalled by three bits according to table 5.32.

**Table 5.32: Signalling format for the  $\alpha$  values**

Bits $s_{27}, s_{28}, s_{29}$	$\alpha$ value
000	Non hierarchical
001	$\alpha = 1$
010	$\alpha = 2$
011	$\alpha = 4$
100	Reserved
101	Reserved
110	Reserved]
111	Reserved

#### 5.7.4.3.2.7 Code rates

Non-hierarchical channel coding and modulation requires signalling of one code rate  $r$ . Two different code rates may be applied to two different levels of the modulation with the aim of achieving hierarchy. In DVB-SH mode, the four bits  $s_{30}$  to  $s_{33}$  shall have the following meaning:

- In super-frames with the frame number 1, bits provides HP code rates, as defined in the table 5.33.
- In super-frames with the frame number 3, bits provides LP code rates, as defined in the table 5.33.

In no hierarchical modulation mode, the LP Punct\_Pad\_ID is set to the default value '0' (4 bits  $s_{30}$  to  $s_{33}$  are equal to '0').

**Table 5.33: Signalling format for each code rate**

Bits $s_{30}, s_{31}, s_{32}, s_{33}$	Punct_Pat_ID	Code Rate
0000	0	1/5
0001	1	2/9
0010	2	1/4
0011	3	2/7
0100	4	1/3
0101	5	1/3
0110	6	2/5
0111	7	2/5
1000	8	1/2
1001	9	1/2
1010	10	2/3
1011	11	2/3
1100	12	RFU
1101	13	RFU
1110	14	RFU
1111	15	RFU

In super-frames with the frame number 2 and 4, bits  $s_{30}$  to  $s_{33}$  provide interleaver delay profiles according to clause 5.7.4.3.2.13.

#### 5.7.4.3.2.8 Super Frame number

SH frame synchronization requires signalling of the super frame number inside the SH frame for modes having more than one super-frame per SH frame. This is achieved via bit  $s_{35}$ :

- in super-frames with the frame number 1 and 3, bit  $s_{35}$  provides most significant bit;
- in super-frames with the frame number 2 and 4, bits  $s_{35}$  provides least significant bit position as defined in the table 5.34.

For all modes having less than one or only one super-frame per SH frame, the bits are set to 0. For all modes having  $n$  super-frames per SH frame, the super-frame number is expressed modulo  $n$ . The first super-frame of each SH frame is always numbered 0.

**Table 5.34: Signalling format for super frame number**

$S_{35}$ frame 1 and 3, $S_{35}$ frame 2 and 4	Super frame in SH-frame
00	Super frame 1 in the SH frame
01	Super frame 2 in the SH frame
10	Super frame 3 in the SH frame
11	Super frame 4 in the SH frame

#### 5.7.4.3.2.9 Guard Intervals

The value of the guard interval is signalled according to table 5.35:

**Table 5.35: Signalling format for each of the guard interval values**

Bits $s_{36}$ and $s_{37}$	Guard interval values ( $T_G/T_U$ )
00	1/32
01	1/16
10	1/8
11	1/4

#### 5.7.4.3.2.10 Transmission mode

Two bits are used to signal the transmission mode.

**Table 5.36: Signalling format for transmission mode**

Bits $s_{38}$ and $s_{39}$	Transmission mode
00	2k mode
01	8k mode
10	4k mode
11	1k mode

#### 5.7.4.3.2.11 Cell identifier

The eight bits  $s_{40}$  to  $s_{47}$  are used to identify the cell from which the signal comes from. The most significant byte of the cell\_id, i.e.  $b_{15} - b_8$ , shall be transmitted in super-frames with the frame number 1 and 3. The least significant byte of the cell\_id, i.e.  $b_7 - b_0$ , shall be transmitted in super-frames with the frame number 2 and 4. The mapping of bits is according to table 5.37. If the provision of the cell\_id is not foreseen the eight bits shall be set to zero.

**Table 5.37: Mapping of the cell\_id on the TPS bits**

TPS bit number	Frame number 1 or 3	Frame number 2 or 4
$s_{40}$	cell_id $b_{15}$	cell_id $b_7$
$s_{41}$	cell_id $b_{14}$	cell_id $b_6$
$s_{42}$	cell_id $b_{13}$	cell_id $b_5$
$s_{43}$	cell_id $b_{12}$	cell_id $b_4$
$s_{44}$	cell_id $b_{11}$	cell_id $b_3$
$s_{45}$	cell_id $b_{10}$	cell_id $b_2$
$s_{46}$	cell_id $b_9$	cell_id $b_1$
$s_{47}$	cell_id $b_8$	cell_id $b_0$

### 5.7.4.3.2.12 DVB-SH mode

When DVB-SH mode is used, bit  $s_{53}$  is set to 1.

When set to 1, this bit signals redefinition of following bits compared to [1]:

- $s_{30}$  to  $s_{35}$
- $s_{48}$  to  $s_{52}$

In particular bits  $s_{48}$  and  $s_{49}$  do not any more signal DVB-H mode.

### 5.7.4.3.2.13 Interleaver profile

The bits  $s_{30}$  to  $s_{33}$  (multiplexed on frames 2 and 4 hence providing 8 bits capacity over the super frame),  $s_{34}$ ,  $s_{48}$  to  $s_{52}$  (multiplexed on all four frames providing 24 bits capacity over the super frame) give a configuration capacity over one super frame of 32 bits as shown in figure 5.36. In the following,  $B_x$  with  $x$  between 1 and 32 will refer to the  $x^{\text{th}}$  bit used for the interleaver definition, most significant bit first.

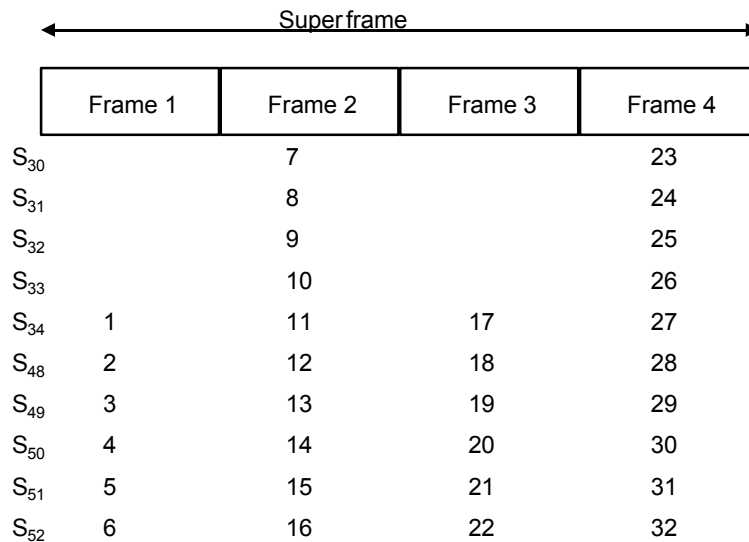

**Figure 5.36: Numbering of TPS bits allocated to interleaver configuration**

NOTE: The definition of the interleaver is common to both transport streams in case of hierarchical modulation.

The interleaver bits enable to signal a wide variety of configurations, some of which may not be suitable for class 1 receivers. To know if it can de-interleave the stream, the receiver has to check if:

- $\text{nof\_late\_taps} > 0$ .
- Punctured code rate remains below 1 ( $\text{code\_rate} * 48 / \text{nof\_late\_taps} < 1$ ).

The signalling assumes a segmentation of the taps into several parts:

- An optional late part of size configurable, the tap length increment being by default the common multiplier.
- A number of slices (including the late part) with a signalled tap length increment; the number of taps in the non-late slice(s) is common to all slices, not signalled since it can be computed if relevant ( $\text{nof\_late\_taps} < 48$  and  $\text{nof\_slices} > 1$ ) by the formula:

$$\begin{aligned} \text{nof\_taps\_per\_non\_late\_slice} &= (48 - \text{nof\_late\_taps}) / (\text{nof\_slices} - 1) \quad (\text{if } \text{nof\_late\_taps} > 0) \\ \text{nof\_taps\_per\_non\_late\_slice} &= 48 / \text{nof\_slices} \quad (\text{if } \text{nof\_late\_taps} = 0) \end{aligned}$$

- An increment between slices expressed in units of SH frames.

**Table 5.38: Interleaver parameters signalling**

Position	Size	Unit	Name	Description	Min	Max	Comment
B1 to B6	6	IU	common_multiplier	Tap length common multiplier	1	63	By default, late part tap length step
B7 to B12	6	N/A	nof_late_taps	Number of taps in the late category	0	48	"0" signals no late part available, "48" signals only late part available
B13 to B18	6	N/A	nof_slices	Number of slices over which data is distributed	1	63	if only late part is used, must be set to 1
B19 to B26	8	SH_frames	slice_distance	Distance between 2 slices	0	255	Must be multiplied with the SH frame capacity in IU and divided by 48 to get increment in IU. Value set to 0 if interleaver applies only to 1 slice
B27 to B32	6	Common_multiplier	non_late_increment	Increment between taps inside non-late slice(s)	0	63	Must be multiplied with common_multiplier to get increment in IU; value 0 is used in case of full late configuration

**Table 5.39: Typical configurations**

Name	Terrestrial	Early/late		Uniform/late	Uniform w/time slicing	Uniform w/o time slicing
		Different increments	Same increments			
common_multiplier	$1 \leq \text{Value} \leq 63$	$1 \leq \text{Value} \leq 63$	$1 \leq \text{Value} \leq 63$	$1 \leq \text{Value} \leq 63$	$1 \leq \text{Value} \leq 63$	$1 \leq \text{Value} \leq 63$
nof_late_taps	Value = 48	$0 < \text{Value} < 48$	Value = 0	$0 < \text{Value} < 48$	Value = 0	Value = 0
nof_slices	Value = 1	Value = 2	Value = 2	Value = 2	$1 < \text{Value}$	Value = 1
slice_distance	Value = 0	$0 < \text{Value} \leq 255$	$0 < \text{Value} \leq 255$	Value = 0	$0 < \text{Value} \leq 255$	Value = 0
non_late_increment	Value = 0	$0 \leq \text{Value} \leq 63$	$0 \leq \text{Value} \leq 63$	$0 < \text{Value} \leq 63$	$0 < \text{Value} \leq 63$	$0 < \text{Value} \leq 63$

The configuration with late part with 0 increment and a non-late part non 0 increment is impossible.

#### 5.7.4.3.2.14 Error protection of TPS

The 53 bits containing the TPS synchronization and information (bits  $s_1 - s_{53}$ ) are extended with 14 parity bits of the BCH (67,53,  $t = 2$ ) shortened code, derived from the original systematic BCH (127,113,  $t = 2$ ) code.

Code generator polynomial:

$$h(x) = x^{14} + x^9 + x^8 + x^6 + x^5 + x^4 + x^2 + x + 1.$$

The shortened BCH code may be implemented by adding 60 bits, all set to zero, before the information bits input of an BCH (127, 113,  $t = 2$ ) encoder. After the BCH encoding these null bits shall be discarded, leading to a BCH code word of 67 bits.

#### 5.7.4.3.3 TPS modulation

TPS cells are transmitted at the "normal" power level, i.e. they are transmitted with energy equal to that of the mean of all data cells, i.e.  $E[c \times c^*] = 1$ .

Every TPS carrier is DBPSK modulated and conveys the same message. The DBPSK is initialized at the beginning of each TPS block.

The following rule applies for the differential modulation of carrier  $k$  of symbol  $l$  ( $l > 0$ ) in frame  $m$ :

- if  $s_l = 0$ , then  $\text{Re}\{c_{m,l,k}\} = \text{Re}\{c_{m,l-1,k}\}$ ;  $\text{Im}\{c_{m,l,k}\} = 0$ ;
- if  $s_l = 1$ , then  $\text{Re}\{c_{m,l,k}\} = -\text{Re}\{c_{m,l-1,k}\}$ ;  $\text{Im}\{c_{m,l,k}\} = 0$ .

The absolute modulation of the TPS carriers in the first symbol in a frame is derived from the reference sequence  $w_k$  as follows:

$$\text{Re}\{c_{m,l,k}\} = 2 (1/2 - w_k)$$

$$\text{Im}\{c_{m,l,k}\} = 0$$

## 5.7.5 Baseband shaping and quadrature modulation

Spectrum characteristics as defined in clause 4.8.1 of reference [1] are used.

The OFDM symbols constitute a juxtaposition of equally-spaced orthogonal carriers. The amplitudes and phases of the data cell carriers are varying symbol by symbol according to the mapping process described in clause 5.7.3.

The power spectral density  $P_k(f)$  of each carrier at frequency:

$$f_k = f_c + \frac{k}{T_u}; \left(-\frac{K-1}{2} \leq k \leq \frac{K-1}{2}\right)$$

is defined by the following expression:

$$P_k(f) = \left[ \frac{\sin \pi (f - f_k) T_s}{\pi (f - f_k) T_s} \right]^2$$

The overall power spectral density of the modulated data cell carriers is the sum of the power spectral densities of all these carriers. Because the OFDM symbol duration is larger than the inverse of the carrier spacing, the main lobe of the power spectral density of each carrier is narrower than twice the carrier spacing.

## Annex A (normative): SH frame Initialization Packet (SHIP)

### A.1 Introduction

The SHIP is an MPEG-2 compliant Transport Stream (TS) packet, made up of a 4-byte header and a 184-byte data field. The organization of the SHIP is shown in table A.1.

Each SH frame contains exactly one SH frame Initialization Packet (SHIP). Actual position may vary in an arbitrary way from SH frame to SH frame while recommended position is the start of the SH frame. The pointer value in the SHIP is used to indicate the start of the following SH frame.

In addition to traditional information, the SHIP may also be used to provide synchronization functions between the MPE and physical layers in order to optimize their integration. However, for modes where the number of SH frames per superframe is higher than one as given in table 5.10, the synchronization function is mandatory and its usage specified in clause A.4.9.

### A.2 SHIP header

**Table A.1: SH frame Initialization Packet (SHIP)**

Syntax	Number of bits	Identifier
SH_frame_initialization_packet(){		
transport_packet_header	32	Bslbf
synchronization_id	8	Uimsbf
section_length	8	Uimsbf
Pointer	16	Uimsbf
periodic_flag	1	Bslbf
future_use	14	Bslbf
SH_use	1	Bslbf
synchronization_time_stamp	24	Uimsbf
maximum_delay	24	Uimsbf
tps_ship	32	bslbf
individual_addressing_length	8	uimsbf
for (i=0;i<N;i++){		
<i>tx_identifier</i>	16	<i>uimsbf</i>
<i>function_loop_length</i>	8	<i>uimsbf</i>
for (i=0;i<N;i++){		
<i>function()</i>		
}		
}		
crc_32	32	rpchof
for (i=0, i<N,i++){		
stuffing_byte	8	uimsbf
}		
}		
NOTE 1: Optional parameters are shown in italic.		
NOTE 2: All parameter values in the SHIP M apply to SH frame M+1, i.e. to the SH frame pointed out by the pointer, except for the tps_ship which describes the parameters of SH frame M+2.		
NOTE 3: The length of a SH-IP shall always be 188 bytes.		

**transport\_packet\_header:** The transport\_packet\_header shall comply with ISO/IEC 13818-1 [4], clause 2.4.3.2, tables 3 and 4. The PID value for the SH frame initialization Packet (SHIP) shall be 0x15. The payload\_unit\_start\_indicator is not used by the SFN synchronization function and shall be set to 1. The transport\_priority value is not used by the SFN synchronization function and shall be set to 1. The transport\_scrambling\_control value shall be set to 00 (not scrambled). The adaptation\_field\_control value shall be set to 01 (payload only). All other parameters are according to ISO/IEC 13818-1 [4], clause 2.4.3.2. The Transport Packet Header (TPH) is mandatory.

## A.3 Mandatory parameters

**synchronization\_id:** The synchronization\_id is used to identify the synchronization scheme used (see table A.2).

**Table A.2: Signalling format for the synchronization\_id**

synchronization_id	Function
0x00	SFN synchronization
0x01 to 0xFF	Future use

**section\_length:** The section\_length specifies the number of bytes following immediately after the section\_length field until, and including, the last byte of the crc\_32 but not including any stuffing\_byte. The section\_length shall not exceed 182 bytes.

**pointer:** The pointer is a 2-byte binary integer indicating the number of transport packets between the SHIP and the first packet of the succeeding SH frame. The range of the pointer depends on the constellation, code and data rate used for emission.

**periodic\_flag:** Indicates if a periodic or an aperiodic insertion of the SHIP is performed. Periodic insertion means that the value of the pointer is not time varying. A "0" indicates aperiodic mode and a "1" indicates periodic mode. All SFN "SYNC systems" shall be able to handle both aperiodic and periodic mode.

**future\_use:** Reserved for future use.

**SH\_use:** Set to 1 to differentiate SHIP compared to DVB-T MIP.

**synchronization\_time\_stamp:** The synchronization\_time\_stamp of SH-IP<sub>M</sub> contains the time difference, expressed as a number of 100 ns steps, between the latest pulse of the "one-pulse-per-second" reference (derived e.g. from GPS) that precedes the start of the SH frame M+1 and the actual start (i.e. beginning of first bit of first packet) of this SH frame M+1. The unit is 100 ns and the range of maximum\_delay is 0x000000 to 0x98967F, this equals a maximum delay of 1s).

**maximum\_delay:** The maximum\_delay contains the time difference between the time of emission of the start of SH frame M+1 of the DVB-SH signal from the transmitting antenna and the start of SH frame M+1 at the SFN adapter, as expressed by the value of its synchronization\_time\_stamp in the SH-IP<sub>M</sub>. The value of maximum\_delay shall be larger than the sum of the longest delay in the primary distribution network and the delays in modulators, power transmitters and antenna feeders. The unit is 100 ns and the range of maximum\_delay is 0x000000 to 0x98967F, this equals a maximum delay of 1 s.

**tps\_ship:** The tps\_ship consists of 32 bits, P<sub>0</sub> to P<sub>31</sub>. The relationship between the TPS as defined in 5.7.4.3 and tps\_ship is described in table A.3. Due to the bit reuse between frames within the superframe, the SHIP will be numbered between 0 and 3 via the frame number field (bits s<sub>23</sub>, s<sub>24</sub> in table 5.2.9, bits P<sub>0</sub>, P<sub>1</sub> in tps\_ship), hence enabling the same reuse pattern as the superframe.

In addition, in cases of several SH Frames per OFDM Super Frame, the SHIP Frame Number shall be used for grouping the SH Frames in the OFDM super frames. In case of 2 SH Frames per OFDM Super Frame, SH Frames containing SHIP packets with Frame Number 1 (P<sub>0</sub>,P<sub>1</sub> = 0,0) and 2 (P<sub>0</sub>,P<sub>1</sub> = 0,1) will be grouped in the same OFDM Super Frame, SH Frames containing SHIP packets with Frame Number 3 (P<sub>0</sub>,P<sub>1</sub> = 1,0) and 4 (P<sub>0</sub>,P<sub>1</sub> = 1,1) will be grouped in the same OFDM Super Frame. In case of 4 SH Frames per OFDM Super Frame, SH Frames containing SHIP packets with Frame Number 1, 2, 3 and 4 will be grouped in the same OFDM Super Frame, starting with the SH frame number 1.

**Table A.3: Relationship between TPS (as defined in clause 5.7.4.3) and tps\_ship**

Bit number (TPS)	Format	Purpose/Content	Bit number (tps_ship)
S <sub>0</sub> to s <sub>22</sub>	See TPS definition in clause 5.7.4.3.2		Not used
S <sub>23</sub> to s <sub>34</sub>	See TPS definition in clause 5.7.4.3.2		P <sub>0</sub> to P <sub>11</sub>
S <sub>35</sub>	See TPS definition in clause 5.7.4.3.2	Super Frame number	Not used
S <sub>36</sub> to s <sub>39</sub>	See TPS definition in clause 5.7.4.3.2		P <sub>12</sub> to P <sub>15</sub>
S <sub>40</sub> to s <sub>47</sub>	See TPS definition in clause 5.7.4.3.2	Cell identifier	Not used
S <sub>48</sub> to s <sub>53</sub>	See TPS definition in clause 5.7.4.3.2		P <sub>16</sub> , P <sub>21</sub>
S <sub>54</sub> to s <sub>67</sub>	See TPS definition in clause 5.7.4.3.2	BCH code	Not used
-	see table A.4: "Signalling format for the bandwidth"	Bandwidth of the RF channel	P <sub>22</sub> , P <sub>23</sub>
-	see table A.5: "Signalling format for the bit stream priority"	The priority of the transport stream	P <sub>24</sub>
-		Future use	P <sub>25</sub> to P <sub>31</sub>
NOTE: There are 7 bits allocated for future use in tps_ship and they shall be set to 0, whereas there are no bits allocated for future use in the TPS as defined in table 5.10.			

NOTE: in cases there are several frames per SH frame, P0 and P1 shall be equal to '00'.

**Table A.4: Signalling format for the bandwidth**

Bits P <sub>22</sub> , P <sub>23</sub>	Bandwidth
00	7 MHz
01	8 MHz
10	6 MHz
11	Other bandwidths than above optionally signalled via bandwidth_function

**Table A.5: Signalling format for the bit stream priority**

Bit P <sub>24</sub>	Transmission mode
0	Low Priority TS
1	Non-hierarchical or High Priority TS

**individual\_addressing\_length:** The individual\_addressing\_length field gives the total length of the individual addressing field in bytes. If individual addressing of transmitters is not performed, the field value is 0x00, indicating that the crc\_32 immediately follows the individual\_addressing\_length. If individual addressing of transmitters is based on multicast addressing, the value 0xFF is used, indicating that groups of transmitters are concerned. If individual\_addressing\_length is strictly set between these two values, the tx\_identifier loop enables to set parameters for individual transmitter.

**crc\_32:** This 32 bit crc\_32 field contains the CRC value that gives a zero output of the registers in the decoder defined in section of the present document, after processing all of the bytes in the SHIP, excluding the stuffing bytes.

**stuffing\_byte:** Every stuffing\_byte has the value 0xFF.

## A.4 Optional SHIP section parameters

**tx\_identifier:** The tx\_identifier is a 16 bit word used to address either an individual transmitter or a multicast group of transmitters. The tx\_identifier value 0x0000 is used as a broadcast address to address all transmitters in the network. If individual\_addressing\_length is equal to 0xFF, then tx\_identifier maps a multicast address scheme. If individual\_addressing\_length is strictly between 0x00 and 0xFF then tx\_identifier maps a unicast address scheme.

**function\_loop\_length:** The function\_loop\_length field gives the total length of the function loop field in bytes.

**function:** The functions are described below. Parameters common to all functions are:

`function_tag`: The `function_tag` specifies the function identification.

`function_length`: The `function_length` field gives the total length of the function field in bytes.

Table A.6 gives the `function_tag` value for the functions defined in the present document. All functions are optional and similar commands could be sent via a separate management network.

**Table A.6: Tag value of functions**

Function	function_tag value
<code>tx_time_offset_function</code>	0x00
<code>tx_frequency_offset_function</code>	0x01
<code>tx_power_function</code>	0x02
<code>private_data_function</code>	0x03
<code>cell_id_function</code>	0x04
<code>Enable_function</code>	0x05
<code>bandwidth_function</code>	0x06
<code>service_loc_function</code>	0x07
<code>service_sync_function</code>	0x08
<code>tdm_function</code>	0x09
<code>group_membership_function</code>	0x0A
<code>Future_use</code>	0x0B to 0xFF

## A.4.1 Transmitter time offset function

The `tx_time_offset_function` is used to apply a deliberate offset in time of the transmitted DVB-SH signal, relative to the reference transmission time (`STS+maximum_delay`) modulo  $10^7$ .

**Table A.7: Function transmitter time offset**

Syntax	Number of bits	Identifier
<code>tx_time_offset_function(){</code>		
<code>function_tag</code>	8	uimsbf
<code>function_length</code>	8	uimsbf
<code>time_offset</code>	16	tcimsbf
<code>}</code>		

`time_offset`: The deliberate time offset of the SH frames. The unit is 100 ns. The range is  $[-32\ 768, 32\ 767] \times 100$  ns.

NOTE: The use of the complete range is not foreseen.

## A.4.2 Transmitter frequency offset function

The `tx_frequency_offset_function` is used to apply a deliberate frequency offset of the centre frequency of the emitted DVB-SH signal relative to the centre frequency of the RF channel.

**Table A.8: Function transmitter frequency offset**

Syntax	Number of bits	Identifier
<code>tx_frequency_offset_function(){</code>		
<code>function_tag</code>	8	uimsbf
<code>function_length</code>	8	uimsbf
<code>frequency_offset</code>	24	tcimsbf
<code>}</code>		

`frequency_offset`: The deliberate frequency offset relative to the centre frequency of the RF channel in use. The unit is 1 Hz. The range is  $[-8\ 388\ 608, 8\ 388\ 607] \times 1$  Hz.

NOTE: The use of the complete range is not foreseen.

### A.4.3 Transmitter power function

The `tx_power_function` can be used to configure the transmitter ERP.

**Table A.9: Function transmitter power**

Syntax	Number of bits	Identifier
<code>tx_power_function () {</code>		
<code>function_tag</code>	8	uimsbf
<code>function_length</code>	8	uimsbf
<code>tx_power</code>	16	uimsbf
<code>}</code>		

`tx_power`: The power of the transmitter is defined as the ERP. The unit is 0,1 dB. The range is  $([0,65535] \times 0,1)$  dBm.

NOTE: The use of the complete range is not foreseen.

### A.4.4 Private data function

The `private_data_function` is used to send private data to the transmitters via the SH-IP.

**Table A.10: Function private data**

Syntax	Number of bits	Identifier
<code>private_data_function() {</code>		
<code>function_tag</code>	8	uimsbf
<code>function_length</code>	8	uimsbf
<code>for (i=0;i&lt;N;i++) {</code>		
<code>private_data</code>	8	bsb1f
<code>}</code>		
<code>}</code>		

`private_data`: The private data can be used for proprietary functions.

### A.4.5 Cell id function

The `cell_id_function` can be used to configure the cell identifier of the transmitter.

**Table A.11: Function cell id**

Syntax	Number of bits	Identifier
<code>cell_id_function() {</code>		
<code>function_tag</code>	8	uimsbf
<code>function_length</code>	8	uimsbf
<code>cell_id</code>	16	uimsbf
<code>wait_for_enable_flag</code>	1	bsb1f
<code>reserved_future_use</code>	7	bsb1f
<code>}</code>		

`cell_id`: The `cell_id` (EN 300 468 [10]) is used to uniquely identify the cell to which the transmitter belongs to.

`wait_for_enable_flag`: If this flag is set to "0" then the `cell_id` within the `cell_id_function` has to be inserted immediately. If this flag is set to "1" then the `cell_id` within the `cell_id_function` has to be inserted immediately after having received the corresponding `enable_function`.

`reserved_future_use`: 7 RFU bits.

## A.4.6 Enable function

The `enable_function` can be used to execute the change of parameters provided by means of other SH-IP functions before.

**Table A.12: Function enable**

Syntax	Number of bits	Identifier
<code>enable_function() {</code>		
<code>function_tag</code>	8	Uimsbf
<code>function_length</code>	8	Uimsbf
<code>for (i=0;i&lt;N;i++){</code>		
<code>enabled_function_tag</code>	8	Bsblf
<code>}</code>		
<code>}</code>		

`enabled_function_tag`: This 8-bit field indicates the function that is enabled by means of the `enable_function`. The coding is according to table A.12.

## A.4.7 Bandwidth function

The bandwidth function can optionally be used to signal the channel bandwidth, when this bandwidth has a value different from 6 MHz, 7 MHz or 8 MHz.

**Table A.13: Function bandwidth**

Syntax	Number of bits	Identifier
<code>bandwidth_function() {</code>		
<code>function_tag</code>	8	uimsbf
<code>function_length</code>	8	uimsbf
<code>ch_bandwidth</code>	7	uimsbf
<code>wait_for_enable_flag</code>	1	bsblf
<code>}</code>		

`ch_bandwidth`: This 8-bit field indicates the OFDM channel bandwidth. The coding is according to table A.14.

**Table A.14: Coding of channel bandwidth**

Bandwidth	Channel bandwidth
0	5 MHz
1	1,7 MHz
2 to 127	Reserved for future use

`wait_for_enable_flag`: If this flag is set to "0" then the bandwidth shall be implemented immediately. If this flag is set to "1" then the bandwidth shall be implemented immediately after having received the corresponding `enable_function`.

## A.4.8 Service localization function

In SH-B architecture, due to the possible non-matching capacity between TDM and OFDM modes, the available capacity can differ between the two modulation schemes. In such a situation, it is important to signal through the service localization function the actual service presence so that transmitter can discard non-relevant service, for instance when capacity of OFDM/terrestrial is higher than capacity of TDM/ satellite:

- Satellite transmitter must discard the service(s) that cannot be sent over satellite TDM.
- Terrestrial transmitter must discard the service(s) that cannot be sent over the local OFDM.

**Table A.15: Function service localization**

Syntax	Number of bits	Identifier
<code>service_localization_function(){</code>		
<code>function_tag</code>	8	uimsbf
<code>function_length</code>	8	uimsbf
<code>for (i=0;i&lt;N;i++){</code>		
<code>service_index</code>	8	uimsbf
<code>}</code>		
<code>wait_for_enable_flag</code>	1	bsb1f
Reserved	7	bsb1f
<code>}</code>		

**service\_index:** Service index number that is localized on this modulator. The service index is comprised between 0 (first service) and 255 (maximum allowed value).

**wait\_for\_enable\_flag:** If this flag is set to "0" then the service\_index within the service\_localization\_function has to be activated immediately. If this flag is set to "1" then the service\_id within the service\_localization\_function has to be activated immediately after having received the corresponding enable\_function.

**reserved:** Set to 0.

## A.4.9 Service synchronization function

Service synchronization function is used to signal:

- The structure of the multiplexing frame in terms of multiplexed physical services.
- The synchronization between the multiplexing frame (and its physical services) with the SH frames.

The multiplexing frame is a fixed repetition pattern sized in 8 TS units (or EFRAMES).

For modes where the number of SH frames per superframe is lower than 1 (see table 5.10), the synchronization function is optional, otherwise it is mandatory and shall follow the following rules:

- at least one service must be indicated (service 0);
- the cumulated length of all signalled services must be higher than or equal in size to the number of EFRAMES per SuperFrame.

A multiplexed physical service is:

- (Mandatory) a dedicated part of the multiplexing frame that has a fixed position and duration within this frame (position and duration are configured in units of 8 TS packets or EFRAMES).
- (Optionally) one or several MPE service.

If present, the function indicates:

- Synchronization mode between MPE and physical services is on.
- List of multiplexed physical services and their duration in EFRAMES.
- First found service start position within the signalled SH frame.

**Table A.16: Function service\_synchronization**

Syntax	Number of bits	Identifier
Service_synchronization_function(){		
function_tag	8	uimsbf
function_length	8	uimsbf
start_flag	1	bsb1f
service_index	8	uimsbf
position_index	10	uimsbf
for (i=0;i<N;i++){		
Length	16	uimsbf
}		
wait_for_enable_flag	1	bsb1f
reserved	4	bsb1f
}		

**start\_flag:** This flag field indicates if there is a service start in the signalled SH frame. If YES, index and position of the service are given by following service\_index and service\_position fields.

**Table A.17: start flag**

Start_flag	Start of a service
0	No
1	Yes

**service\_index:** Service index number that is starting in the SH frame. If other services are starting inside signalled SH frame, only first service is signalled. The service index is comprised between 0 (first service) and 255 (maximum allowed value).

**position\_index:** Starting position of service of number service\_index inside current SH frame, given in units of 8 TS packets (or EFRAMES). Min value is 0, max value is  $2^{10} - 1$  (corresponding to 8184<sup>th</sup> TS packets inside current SH frame).

**length:** Individual service length in units of 8 TS (or EFRAME). Min value is 0, max value is  $2^{16} - 1$ . N is limited by service\_index max value ( $2^8 - 1$ ). Maximum sum of all length must not exceed  $2^{24} - 1$  signalled in EFRAME.

**wait\_for\_enable\_flag:** If this flag is set to "0" then the structure of the multiplexing frame is applied immediately. If this flag is set to "1" then the structure of the multiplexing frame is applied immediately after having received the corresponding enable\_function.

**reserved:** Set to 0.

## A.4.10 TDM function

In the TDM/OFDM mode, the TDM transmitter needs to be configured. This function provides the additional information for configuring the TDM modulator.

**Table A.18: Function TDM**

Syntax	Number of bits	Identifier
tdm_function(){		
function_tag	8	uimsbf
function_length	8	uimsbf
Signalling_version	8	Uimsbf
Stream_identifier	8	uimsbf
Roll-off value	2	uimsbf
TDM modulation mode	2	uimsbf
RFU	3	uimsbf
Frame_Width_CUs	12	uimsbf
Punct_Pad_ID	4	Uimsbf
Common_multiplier	6	Uimsbf
Nof_late_taps	6	Uimsbf
Nof_slices	6	Uimsbf
Slice_distance	8	Uimsbf
Non_late_increment	6	Uimsbf
Wait_for_enable_flag	1	Uimsbf
}		
}		

Signalling\_version: Version number of the DVB-SH signalling format and fixed to 0x01.

Stream identifier: Transport stream identifier.

Roll off value: roll off used for the TDM modulation according to table A.19.

**Table A.19: roll off values**

Roll_off	Value
00	0,35
01	0,25
10	0,15
11	RFU

TDM modulation mode: modulation mode of the TDM modulation according to table A.20.

**Table A.20: TDM modulation mode**

TDM modulation mode	Value
00	QPSK
01	8PSK
10	16APSK
11	RFU

RFU: RFU bits

Frame\_Width\_CUs: DVB-SH frame width in CUs. CUs are used as the unit in order to allow receivers to know the width of the DVB-SH frame.

Punct\_Pad\_ID: ID number of the Turbo code puncturing pattern.

Common\_multiplier: Tap length common multiplier.

Nof\_late\_taps: Number of taps in the late category.

Nof\_slices: Number of slices over which the data is distributed.

Slice\_distance: Distance between two slices.

Non\_late\_increment: Increment between taps inside the non-late slice(s).

**wait\_for\_enable\_flag:** If this flag is set to "0" then the structure of the multiplexing frame is applied immediately. If this flag is set to "1" then the structure of the multiplexing frame is applied immediately after having received the corresponding enable\_function.

## A.4.11 Group membership function

The group membership function enables to attach a transmitter to and detach a transmitter from a multicast group so that common addressing is easily achievable.

When a transmitter is attached to a group of address, say, multicast\_id, it MUST process all functions that are sent with transmitter\_id equal to multicast\_id when individual\_addressing\_length is set to 0xFF.

When the transmitter receives functions through several transmitter\_id (multicast and/or unicast), precedence is first given to the unicast address and then to the lowest multicast\_id.

Group membership function can be sent to individual (individual\_addressing\_length is strictly set between 0x00 and 0xFF values) or groups (individual\_addressing\_length set to 0xFF) of addresses.

**Table A.21: Function group membership**

Syntax	Number of bits	Identifier
multicast_function() {		
function_tag	8	uimsbf
function_length	8	uimsbf
for (i=0; i<N; i++) {		
multicast_id	16	uimsbf
attach_detach	1	bsb1f
wait_for_enable_flag	1	bsb1f
Reserved	6	bsb1f
}		
}		

**Multicast\_id:** The multicast\_id is a 16-bit word used to signal a multicast address.

**Attach\_detach:** if set to 1, transmitter is attached to signalled multicast\_id group. If set to 0, transmitter is detached from signalled multicast\_id group.

**wait\_for\_enable\_flag:** If this flag is set to "0" then attach\_detach function has to be activated immediately. If this flag is set to "1" then attach\_detach function has to be activated immediately after having received the corresponding enable\_function.

**reserved:** Set to '0'.

---

## A.5 CRC decoder model

The 32-bit CRC decoder is specified in figure A.1.

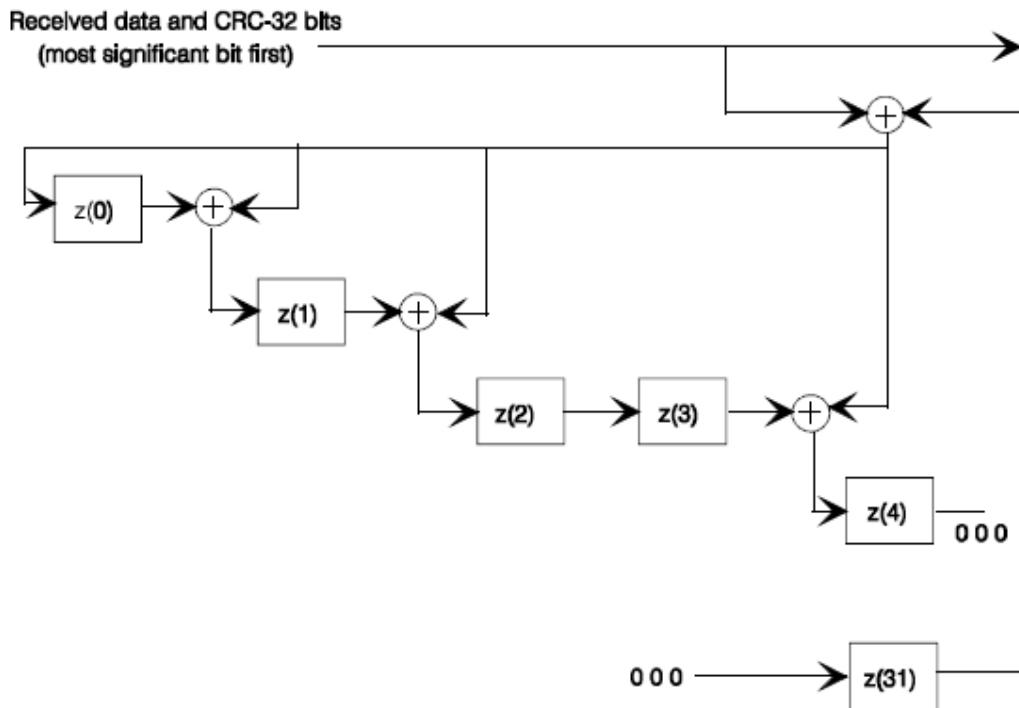

**Figure A.1: 32 bits CRC decoder model**

The 32 bit CRC decoder operates at bit level and consists of 14 adders + and 32 delay elements  $z(i)$ . The input of the CRC decoder is added to the output of  $z(31)$ , and the result is provided to the input  $z(0)$  and to one of the inputs of each remaining adder. The other input of each remaining adder is the output of  $z(i)$ , while the output of each remaining adder is connected to the input of  $z(i+1)$ , with  $i = 0, 1, 3, 4, 6, 7, 9, 10, 11, 15, 21, 22$ , and  $25$  (see figure xxx). This is the CRC calculated with the polynomial:

$$x^{32} + x^{26} + x^{23} + x^{22} + x^{16} + x^{12} + x^{11} + x^{10} + x^8 + x^7 + x^5 + x^4 + x^2 + x + 1$$

Before the CRC processing of the data of a SHIP the output of each delay element  $z(i)$  is set to its initial value "1". After this initialization, each byte of the SHIP is provided to the input of the CRC decoder, including the four `crc_32` bytes, but excluding any stuffing byte. Each byte is shifted into the CRC decoder one bit at a time, with the Most Significant Bit (MSB) first, i.e. from the TS packet sync byte 0x47 (0100 0111) first a "0" enter the CRC decoder, followed by a "1". After shifting the last bit of the last `crc_32` byte into the decoder, i.e. into  $z(0)$  after the addition with the output of  $z(31)$ , the output of all delay elements  $z(i)$  is read. In case of no errors, each of the outputs of  $z(i)$  has to be zero. At the CRC encoder the `crc_32` field is encoded with such value that this is ensured.

---

## Annex B (informative): Bibliography

ETSI TS 101 191: "Digital Video Broadcasting (DVB); DVB mega-frame for Single Frequency Network (SFN) synchronization".

---

## History

Document history			
V1.0.0	August 2007	Public Enquiry	PE 20071214: 2007-08-15 to 2007-12-14
V1.1.0	January 2008	Vote	V 20080314: 2008-01-14 to 2008-03-14
V1.1.1	March 2008	Publication	